

The cylinders of the CY series are produced complying with the ISO 15552 norm; they have bores comprised between 32 and 125 mm. Particularly indicated where precision is important, they are available in different versions: double effect, cushioned and magnetic. The new tube profile makes the cylinder excellent also from the aesthetic side. The production of special cylinders on customer's drawing is possible, as well as the realization of versions with VITON seals.

Les vérins du série CY sont conformes aux normes ISO 15552 et ont alésages du 32 jusqu'à 125 mm. Ils sont en particulier indiqué où la précision est très important, et ils sont disponibles différentes versions: double effet, magnétique ou non, avec o sans amorti.

Le nouveau profile du tube, rend le cylindre intéressant aussi du point de vue esthétique.

La production du vérins speciaux est possible selon le dessin du client, et est aussi possible l'usage des joints en VITON.

I cilindri serie CY di Airwork sono realizzati rispettando la normativa ISO 15552 ed hanno alesaggi compresi tra 32 e 125 mm.

Doppio effetto, ammortizzati e magnetici sono indicati dove è richiesta precisione ed affidabilità. Il nuovo profilo della camicia rende il prodotto interessante anche dal punto di vista estetico. Possibili realizzazioni speciali a disegno e guarnizioni in Viton per alte temperature.



ORDERING CODE / CODIFICATION / CHIAVE DI CODIFICA

CY 00 1 000 0000

Stroke / Course / Corsa
Ø Cylinder / Ø Vérin / Ø Cilindro

SEALS / JOINTS / GUARNIZIONI

- 1 = polyurethane / polyuréthane / poliuretano
- 3 = viton / viton / viton (aluminium piston / piston en aluminium / pistone in alluminio)
- 4 = seal rod for hard use / joint tige pour utilisation lourde / guarnizione stelo per uso pesante
- 6 = viton only rod / viton côté tige / viton solo stelo
- A = aluminum piston with polyurethane seals / piston en aluminium avec joints en polyuréthane / pistone in alluminio con guarnizioni in poliuretano

VERSION / VERSION / VERSIONE

- 01 = double acting / double effet / doppio effetto
- 03 = through rod / tige traversante / stelo passante
- 05 = for rod lock BS series / sur longueur pour bloqueur BS / con extrastelo per bloccastelo BS
- 07 = with inox rod / tige inox / con stelo inox
- 21 = tandem double push / tandem double poussée / tandem doppia spinta
- 23 = tandem double stroke / tandem double course / tandem doppia corsa
- 25 = tandem contrasted / tandem opposé / tandem contrapposti
- 31 = with rubber bellow / avec soufflet / con soffiello
- 33 = with rod lock BS series assembled / avec bloqueur de tige serie BS monté / con bloccastelo serie BS montato

VERSION / VERSION / VERSIONE

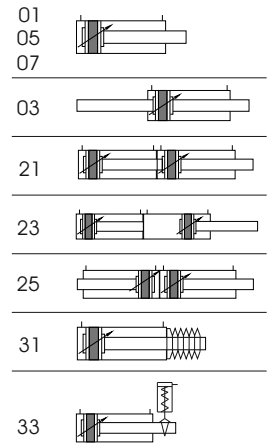

TECHNICAL DATA / DONNÉES TECHNIQUES / DATI TECNICI

Sizes / Alésage / Alesaggi	Ø32-40-50-63-80-100-125
Standard strokes / Course standard / Corse standard	mm 25-50-80-100-125-160-200-250-320-350-400-500-600-700-800-900-1000
Fluid / Fluide / Fluido	Lubricated or non lubricated air / Air lubrifié ou non / Aria con o senza lubrificazione
Operating temperature range / Température d'utilisation / Temperatura di esercizio	Poliurethane / Polyuréthane / Poliuretano: -20C° +80C° / Viton: -10C° +150C°
Max operating pressure / Pression max d'utilisation / Pressione massima di esercizio	10 bar
Force / Force / Forze sviluppate -	Technical informations page / Page informations techniques / Pagina dati tecnici
Air consumption / Consommation d'air / Consumo aria	Technical informations page / Page informations techniques / Pagina dati tecnici

TUBE PROFILE / TUBE PROFILE / PROFILO TUBO

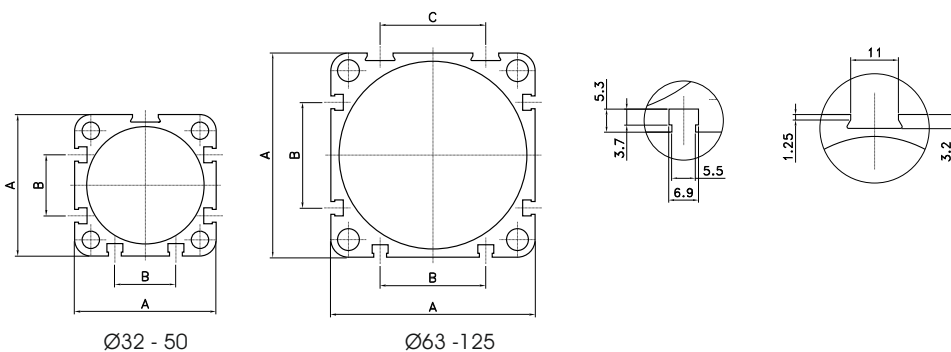

Ø	A	B	C
32	44.5	17	--
40	50.5	23	--
50	60.3	26	--
63	70	37	35
80	87	45	45
100	106	50	46
125	132	56	50

COMPONENTS / COMPOSANTS / COMPONENTI

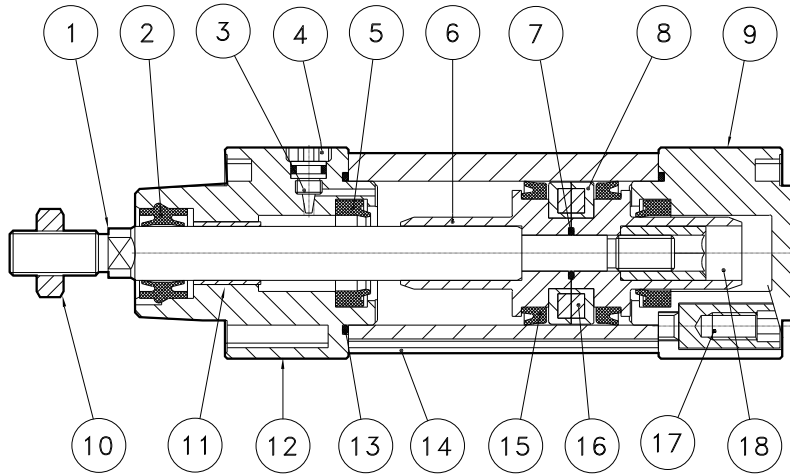

pos.	description / description / descrizione /	material / matériel / materiale
1	rod / tige / stelo	steel C40 chromed / acier C40 chromé / acciaio C40 cromato
2	rod seal / joints tige / guarnizione stelo	polyurethane / PU / poliuretano
3	regulator cushion screw / vis réglage amortissement / vite reg. ammortizzo	nickel brass / laiton nickelé / ottone nichelato
4	stop cushion screw / stop vis / grano ferma vite	nickel brass / laiton nickelé / ottone nichelato
5	cushion seal / joint amortissement / guarnizione ammortizzo /	polyurethane / PU / poliuretano
6	half piston / semi piston / semipistone	POM / alluminio / aluminium / aluminium
7	o-ring	NBR
8	guide piston / guide piston / guida pistone	POM
9	rear cap / fond postérieur / testata posteriore	alluminio / aluminium / aluminium
10	nut / écrou / dado	steel zinc plate / acier zingué / acciaio zincato
11	guide bush / bague guidage / bussola guida	bronze / bronze / bronzo
12	front cap / fond antérieur / testata anteriore	alluminio / aluminium / aluminium
13	o-ring	NBR
14	tube / tube / tubo	alluminio / aluminium / aluminium
15	piston seal / joint piston / guarnizione pistone	polyurethane / PU / poliuretano
16	magnet / aimant / magnete	plastoferrite
17	fixing cap screw / vis serrant tête / vite serraggio testata	steel zinc plate / acier zingué / acciaio zincato
18	fixing piston nut / écrou / dado fissaggio pistone	steel zinc plate / acier zingué / acciaio zincato

THE KEY POINTS / LES POINTS CLES / I PUNTI DI FORZA

Version with seal for heavy use and difficult environments.

Version avec joint pour utilisation lourde et des environnements difficiles.
Versione con guarnizione per uso pesante e ambienti difficili.

It's possible to have the piston in aluminium or acetal resin.
Il est possible d'avoir le piston en aluminium ou en résine acétal.
E' possibile avere il pistone in alluminio o resina acetlica.

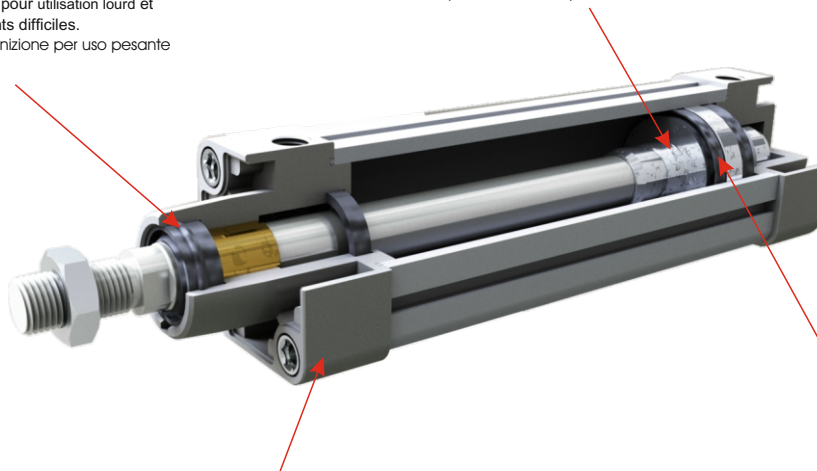

All seals are in polyurethane with high wear resistance.
Tous les joints sont en polyuréthane à haute résistance à l'usure.
Tutte le guarnizioni sono in poliuretano con elevata resistenza all'usura.

Heads are extremely elegant with an high aesthetic impact thanks to epoxy paint which is resistant to corrosion.
Les fonds sont extrêmement élégant avec un haut impact esthétique grâce à la peinture époxy qui est résistante à la corrosion.
Le teste sono estremamente eleganti, con un grande impatto estetico grazie alla vernice epossidica che è anche resistente alla corrosione.

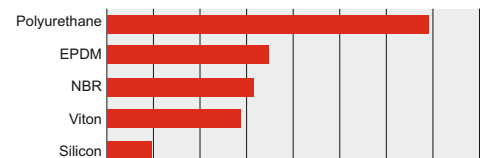

Double acting / Double effet / Doppio effetto

CODE: CY011.Ø.mm



CODE: CY021.Ø.mm

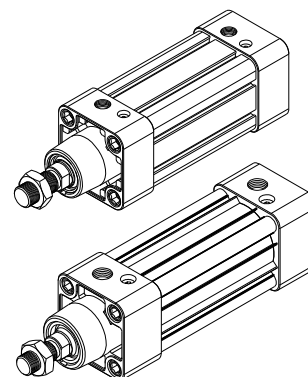
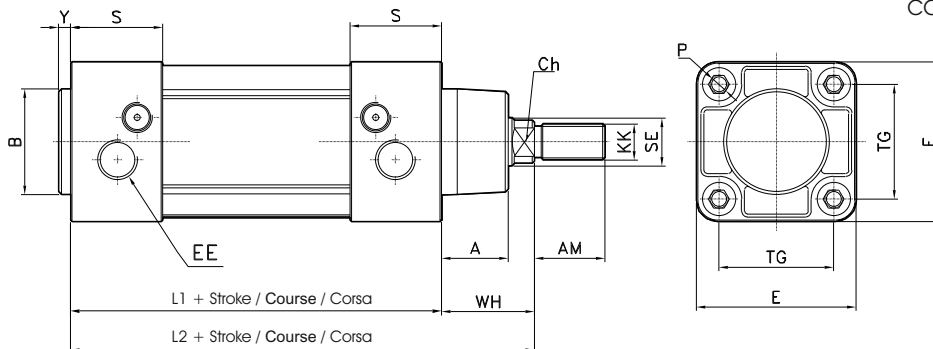

Ø	A	AM (-2)	B ø11	E	EE	Y (-1)	KK	L1	L2	P	S	SE ø	TG	WH	Ch
32	20	22	30	47	G1/8"	4	M10x1.25	94 ± 0.4	120	M6	28	12	32.5	26	10
40	22	24	35	53	G1/4"	4	M12x1.25	105 ± 0.7	135	M6	30.5	16	38	30	13
50	28	32	40	65	G1/4"	4	M16x1.5	106 ± 0.7	143	M8	31	20	46.5	37	16
63	28	32	45	75	G3/8"	4	M16x1.5	121 ± 0.8	158	M8	35	20	56.5	37	16
80	34	40	45	95	G3/8"	4	M20x1.5	128 ± 0.8	174	M10	36	25	72	46	21
100	38	40	55	115	G1/2"	4	M20x1.5	138 ± 1	189	M10	41	25	89	51	21
125	50	54	60	140	G1/2"	5	M27x2	160 ± 1	225	M12	45	32	110	65	27

Through rod / Tige traversante / Stelo passante

CODE: CY031.Ø.mm

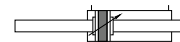

CODE: CY041.Ø.mm

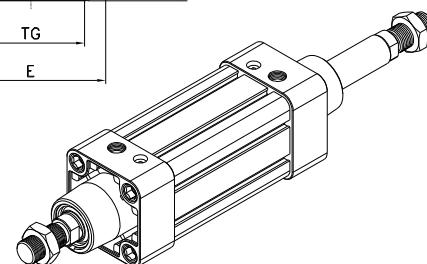
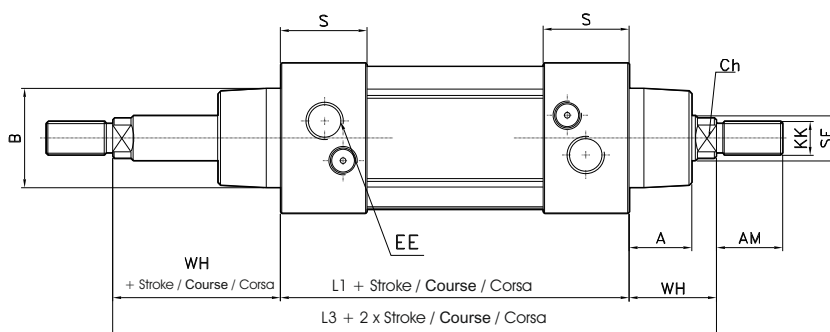
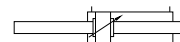

Ø	A	AM (-2)	B ø11	E	EE	KK	L1	L2	L3	P	S	SE ø	TG	WH	Ch
32	20	22	30	47	G1/8"	M10x1.25	94 ± 0.4	120	146 ± 0.4	M6	28	12	32.5	26	10
40	22	24	35	53	G1/4"	M12x1.25	105 ± 0.7	136	165 ± 0.7	M6	30.5	16	38	30	13
50	28	32	40	65	G1/4"	M16x1.5	106 ± 0.7	143	180 ± 0.7	M8	31	20	46.5	37	16
63	28	32	45	75	G3/8"	M16x1.5	121 ± 0.8	158	195 ± 0.8	M8	35	20	56.5	37	16
80	34	40	45	95	G3/8"	M20x1.5	128 ± 0.8	174	220 ± 0.8	M10	36	25	72	46	21
100	38	40	55	115	G1/2"	M20x1.5	138 ± 1	189	240 ± 1	M10	41	25	89	51	21
125	50	54	60	140	G1/2"	M27x2	160 ± 1	225	290 ± 1	M12	45	32	110	65	27

Tandem double push / Tandem double poussée / Tandem doppia spinta

CODE: CY211.Ø.mm



Tandem double stroke / Tandem double course / Tandem doppia corsa

CODE: CY231.Ø.mm

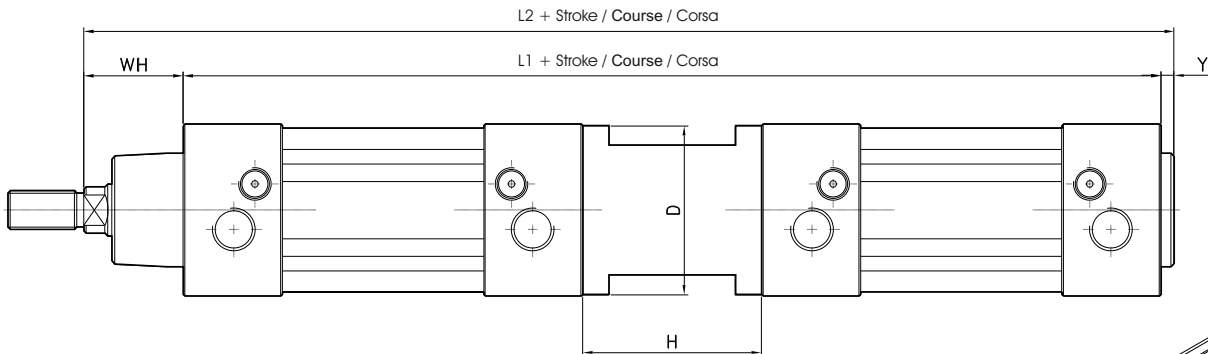

Ø	H	D	WH	L1	L2	Y
32	55	45	26	243 ± 0.4	273	4
40	55	52	30	265 ± 0.7	299	4
50	68	65	37	280 ± 0.7	321	4
63	68	75	37	314 ± 0.8	351	4
80	92	95	46	348 ± 0.8	398	4
100	92	115	51	368 ± 1	423	4
125	120	140	65	440 ± 1	510	5

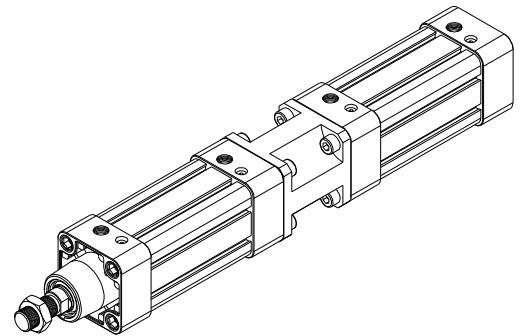

Tandem contrasted / Tandem opposé / Tandem contrapposti

CODE: CY251.Ø.mm



CODE: CY261.Ø.mm

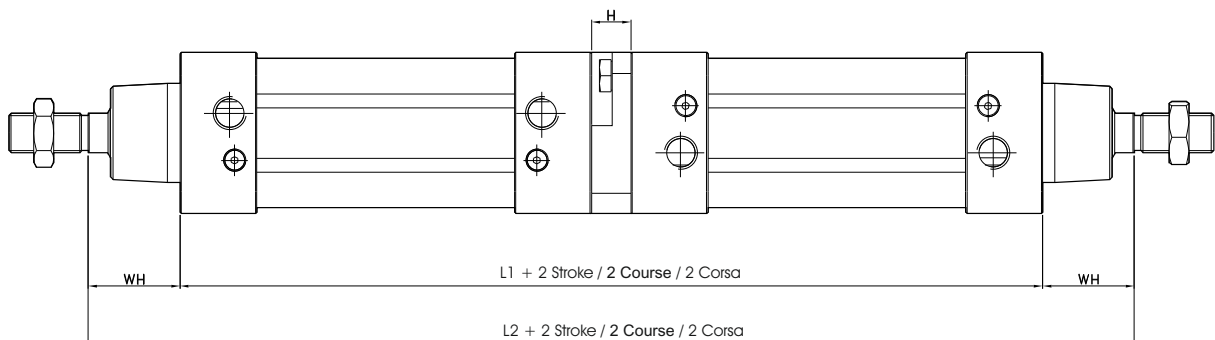

Ø	H	WH	L1	L2
32	12	26	200 +/- 0.4	252
40	12	30	222 +/- 0.7	282
50	16	37	228 +/- 0.7	302
63	16	37	258 +/- 0.8	332
80	20	46	276 +/- 0.8	368
100	20	51	296 +/- 1	398
125	30	65	350 +/- 1	480

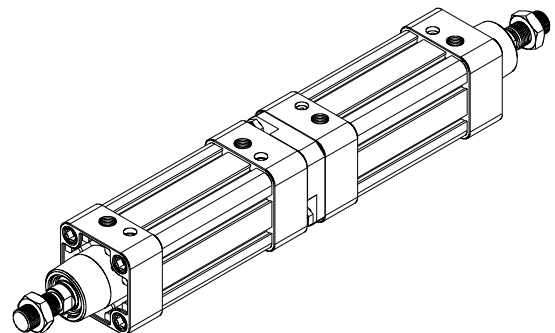

CYLINDERS ISO 15552
VERINS ISO 15552 - CILINDRI ISO 15552
Actuators / Actionneurs / Attuatori

With rubber bellow / Avec soufflet / Con soffiello

CODE: CY311.Ø.mm

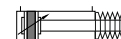

CODE: CY321.Ø.mm

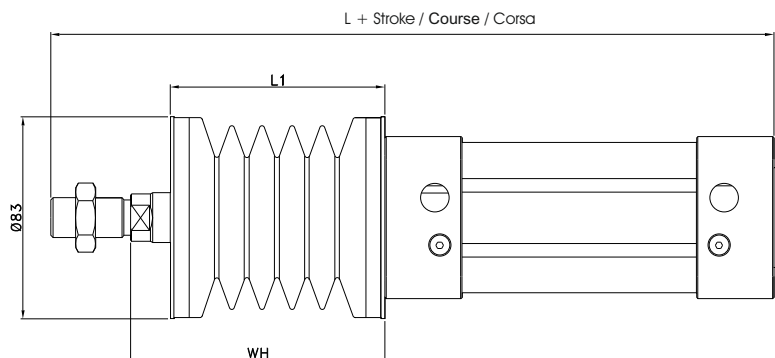
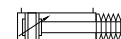

Ø	Stroke/Course/Corsa <400 mm			Stroke/Course/Corsa <800 mm			Stroke/Course/Corsa <1200 mm		
	L	L1	WH	L	L1	WH	L	L1	WH
32	222	90	106	274	142	158	332	200	216
40	235	90	106	287	142	158	345	200	216
50	244	90	106	296	142	158	354	200	216
63	259	90	106	311	142	158	369	200	216
80	274	90	106	326	142	158	384	200	216
100	284	90	106	336	142	158	394	200	216

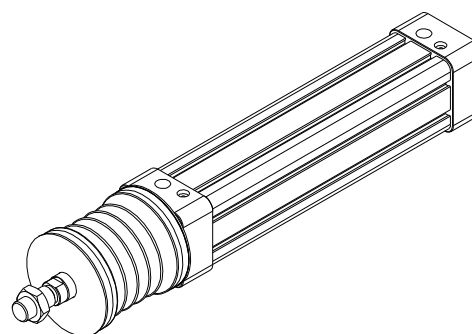

With rod lock BS series assembled
Avec bloqueur de tige serie BS monté
Con bloccastelo serie BS montato

CODE: CY331.Ø.mm



CODE: CY341.Ø.mm

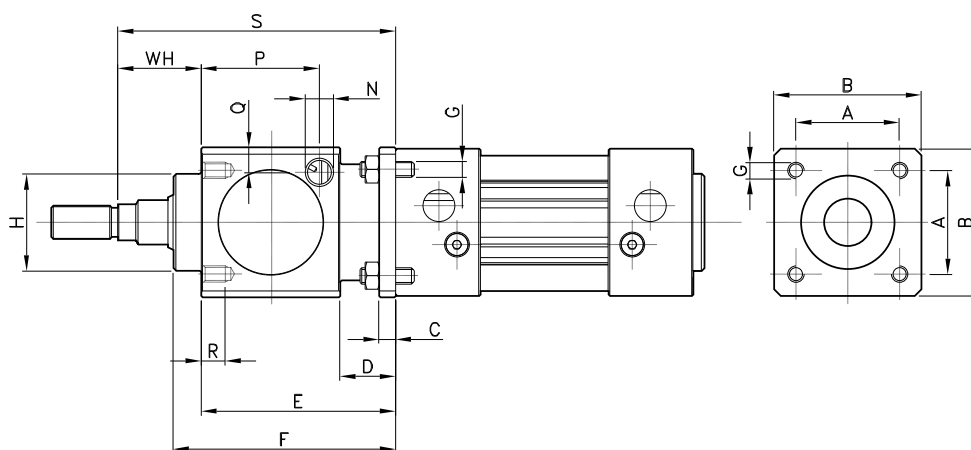
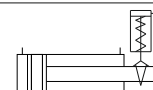

Ø	A	B	C	D	E	F	G	H	N	P	Q	R	S	T
32	32.5	47	6	20	60	67.5	M6	30	1/8"G	33.25	9	8	86	60
40	38	54	6	20	70	80	M6	34.9	1/8"G	42.5	9	8	100	70
50	46.5	65	8	24	90	100	M8	40	1/8"G	58	12.5	12	127	90
63	56.5	75	8	24	90	100	M8	45	1/8"G	59	17.5	12	127	90
80	72	95	12	32	110	120	M10	45	1/4"G	69	17.5	16	156	110
100	89	114	12	32	110	120	M10	55	1/4"G	69	20	16	161	110
125	110	138	20	45	140	156	M12	60	1/4"G	84.5	19	20	205	140

