



RKL 160

Rotary vane compressor

CVS develops and manufactures compressors specifically designed for installation in trucks. The development is made in close collaboration with our customers. This guarantees the optimum product for your application.



The oil free rotary vane compressor

The oil free compressor RKL was developed especially for the high requirements on mounting in liquid tankers.

Features

- » High quality compressors from CVS for reliable discharge
- » Durable and robust design guarantee long lasting performance and high operating hours
- » Compact and light-weight compressors for higher payload on the tanker

Compressors with system

The compressor RKL delivers a volume flow between 116 up to 154 m³/h / 92 - 123 cfm. An efficient cooling system of the RKL 160 ensures improved service life.



Advantages

- » Variable mounting brackets
- » Optimized cooling
- » Clockwise or counter-clockwise rotation
- » Low weight
- » Compact design
- » Variable position from suction and pressure flange
- » Drive via hydraulic motor or directly via cardan shaft possible
- » Permanent lubrication for bearings
- » 2.5 bar g (35.5 psig) operating pressure for the complete speed range possible
- » Fan and fan cover made of aluminium



Dimensions

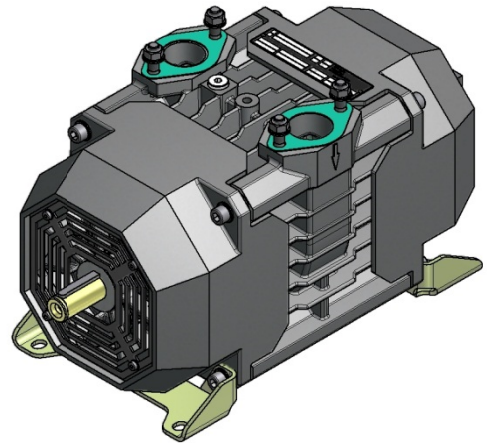
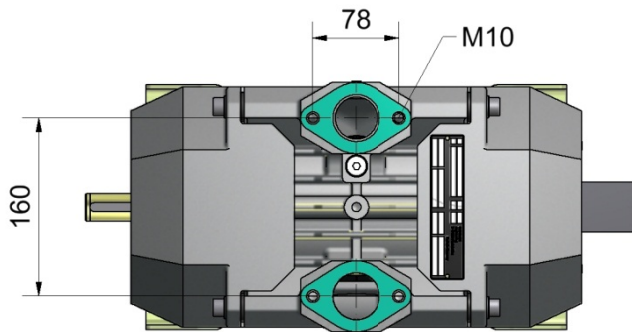
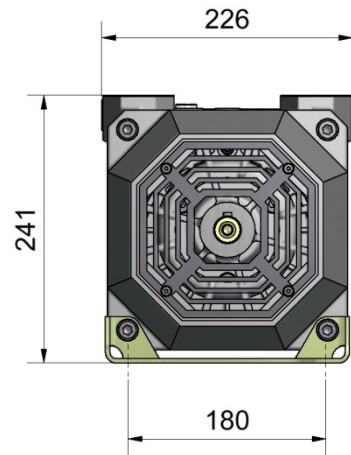
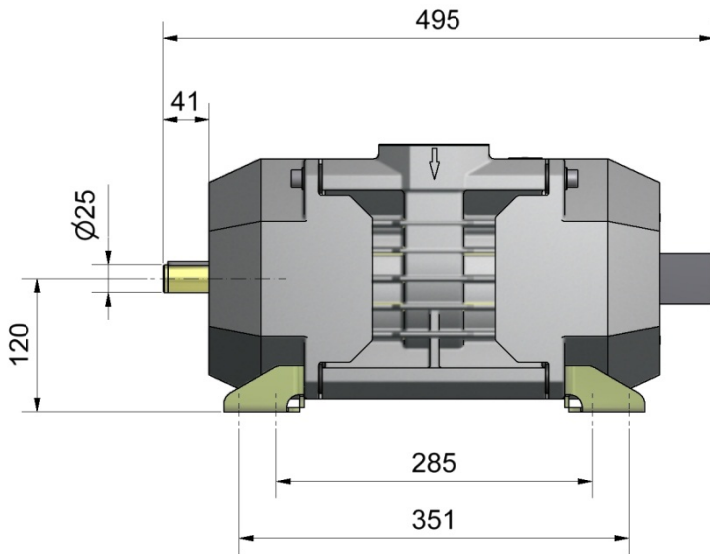

Technical data

		RKL 160
Volume flow at free air	m³/h / cfm	116 - 154 / 68 - 91
Volume flow at 2 bar g / 28.4 psig	m³/h / cfm	92 - 123 / 54 - 72
Max. operating pressure	bar / psig	2.5 / 35.5
Speed	1/min / rpm	1200 - 1600
Power requirement at 2.0 bar g / 28.4 psig	kW / hp	6.5 – 8.6 / 8.9 – 11.7
Weight	kg / lb	33 / 73

Technical subject to alteration