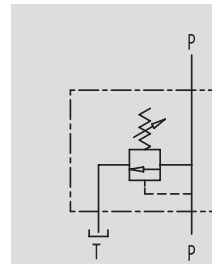
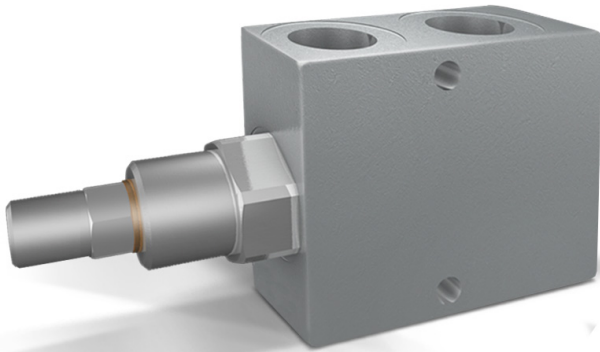

VALVOLE DI MASSIMA PRESSIONE IN LINEA

TIPO / TYPE
VMP L D5SCHEMA IDRAULICO
HYDRAULIC DIAGRAMIN LINE MOUNTING
RELIEF VALVE**IMPIEGO:**

Valvola utilizzata per limitare la pressione di un circuito idraulico ad un determinato valore di taratura. Al raggiungimento di tale valore la valvola si apre e scarica la pressione in modo che questa non salga oltre il valore di taratura.

MATERIALI E CARATTERISTICHE:

Corpo: acciaio zincato
Componenti interni: acciaio temprato termicamente e rettificato
Guarnizioni: BUNA N standard
Tenuta: a cono guidato. Trafilamento trascurabile

MONTAGGIO:

Collegare il ramo del circuito in pressione a P e il ramo di scarico a T. L'attacco P è reversibile.

A RICHIESTA

- molle per diversi campi di taratura (vedi tabella)
- pressione di taratura diversa da quella standard (CODICE/T000 specificando il valore di taratura)

PRESSIONE / PORTATA
PRESSURE / FLOW

USE AND OPERATION:

The relief valve provides overload protection in a fast and accurate way: when it reaches pressure setting, the valve open allowing pressure relief in order not to exceed this setting.

MATERIALS AND FEATURES:

Body: zinc-plated steel
Internal parts: hardened and ground steel
Seals: BUNA N standard
Poppet type: minor leakage.

APPLICATIONS:

Connect circuit port with pressure to P and tank port to T. Port P is reversible.

ON REQUEST

- different setting range (see the table)
- other setting available (CODE/T000 please specify the desired setting)

Temperatura olio: 50 °C - Viscosità olio: 30 cSt
Oil temperature: 50 °C - Oil viscosity: 30 cSt

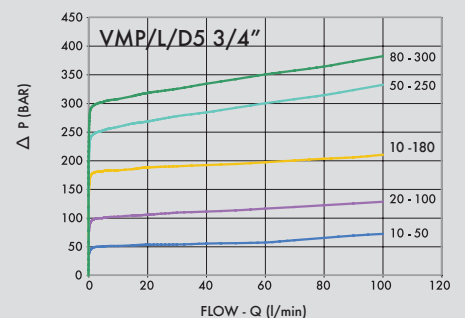
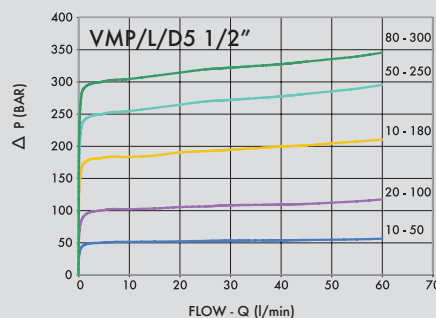
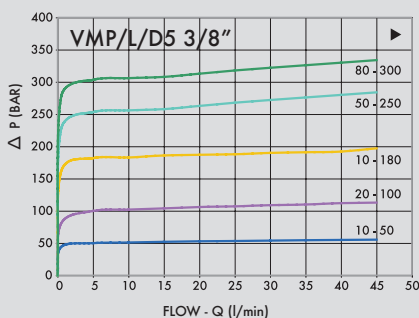



CODICE
CODE

SIGLA
TYPE

PORTATA MAX
MAX FLOW
Ll. / min

V0691/000*

VMP/L/D5 3/8"

45

V0692/000*

VMP/L/D5 1/2"

70

V0693/000*

VMP/L/D5 3/4"

90

*000 = specificare valore della molla desiderata. Vedi tabella sotto.
*000 = please specify the desired setting range. See the table below.

4

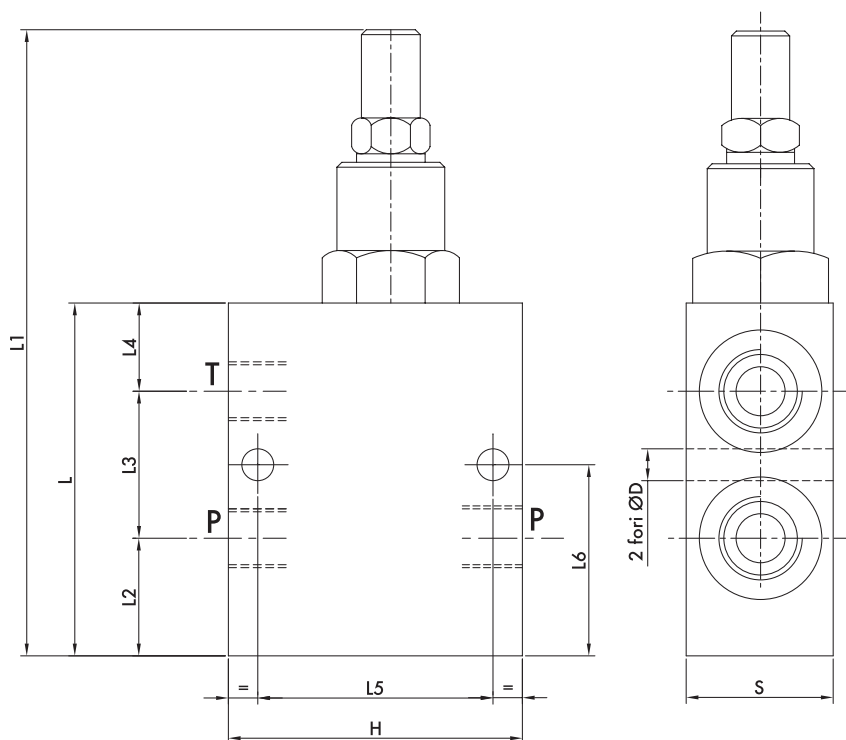

CODICE CODE	SIGLA TYPE	P - T GAS	ØD mm	L mm	L1 mm	L2 mm	L3 mm	L4 mm	L5 mm	L6 mm	H mm	S mm	PESO WEIGHT kg
V0691/000*	VMP/L/D5 3/8"	G 3/8"	6,5	72	126	24	31	17	48	40	60	30	0,922
V0692/000*	VMP/L/D5 1/2"	G 1/2"	6,5	72	126	22	35	15	48	40	60	30	0,870
V0693/000*	VMP/L/D5 3/4"	G 3/4"	8,5	100	154	32	44	24	54	54	70	40	1,812

CODICE CODE	CAMPO DI TARATURA SETTING RANGE (Bar)	INCREMENTO / GIRO PRESSURE INCREASE (bar/Turn) Q= 4l/min	TARATURA STANDARD STANDARD SETTING (Bar)
COD/050	10 - 50*	7	30
COD/100	20 - 100	12	75
COD/180	10 - 180	30	90
COD/250	50 - 250	45	130
COD/300	80 - 300	50	150

REGOLAZIONE - ADJUSTMENT

CODICE/V • CODE/V	Volantino • Handknob
CODICE/PP • CODE/PP	Predisposizione alla piombatura • Arranged for sealing cap
CODICE/P • CODE/PP	Piombatura • Sealing cap

*Per tarature inferiori a 70 Bar: Q = 12 l/min *For setting less than 70 Bar: Q = 12 l/min