

BENT AXIS PISTON MOTORS SERIES "HPM" FLANGE ISO 3019-2

HPM

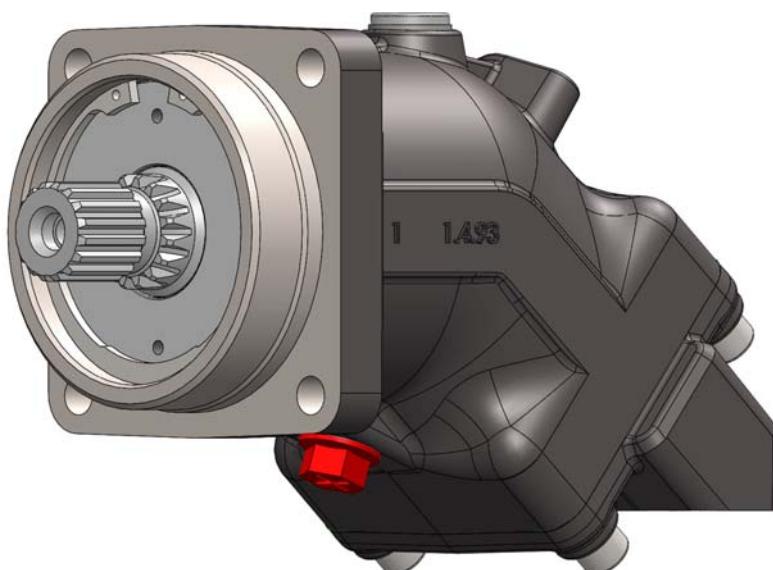
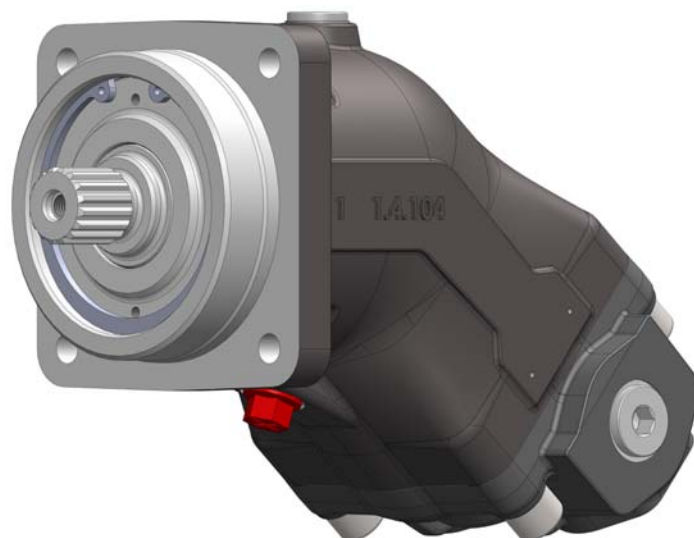
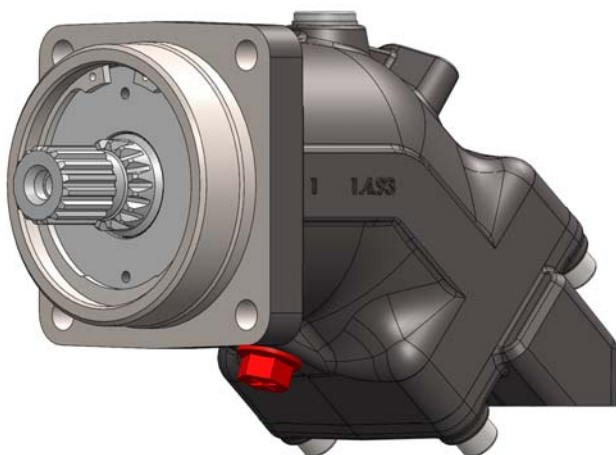

Codice fascicolo:997-400-24411

Data: Venerdì 28 settembre 2018

Rev: AL

Codice foglio:997-244-00011

pag.3

OMFB
HYDRAULIC COMPONENTS

O.M.F.B. S.p.A. Hydraulic Components

We reserve the right to make any changes without notice.

Edition 2016.04 No reproduction, however partial, is permitted.

Via Cave, 7/9 25050 Provaglio d'Iseo (Brescia) Italy Tel.: +39.030.9830611
Fax: +39.030.9839207-208 Internet:www.omfb.it e-mail:info@omfb.it

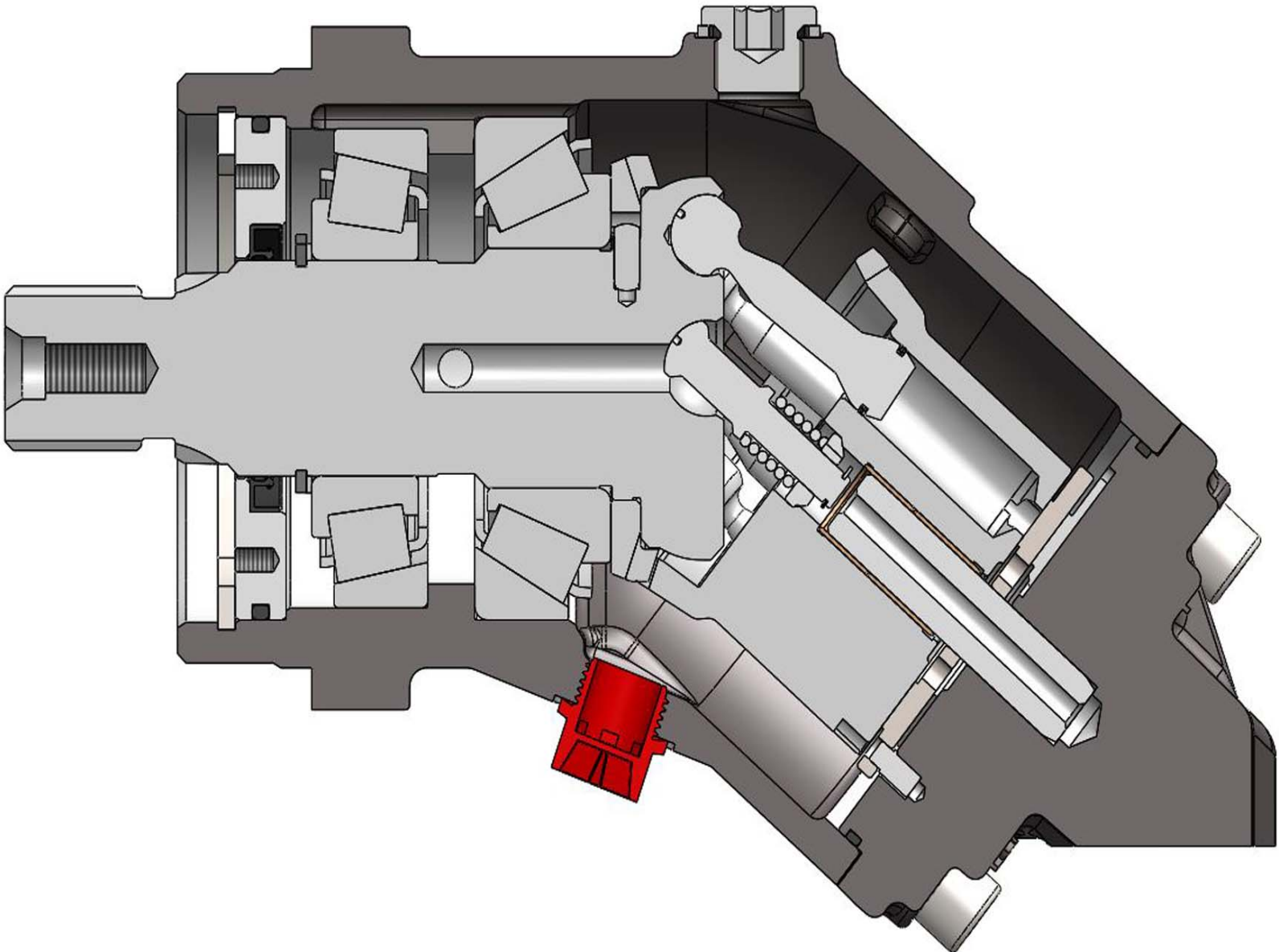

SECTIONS

HPM MOTORS - 2 PARTS

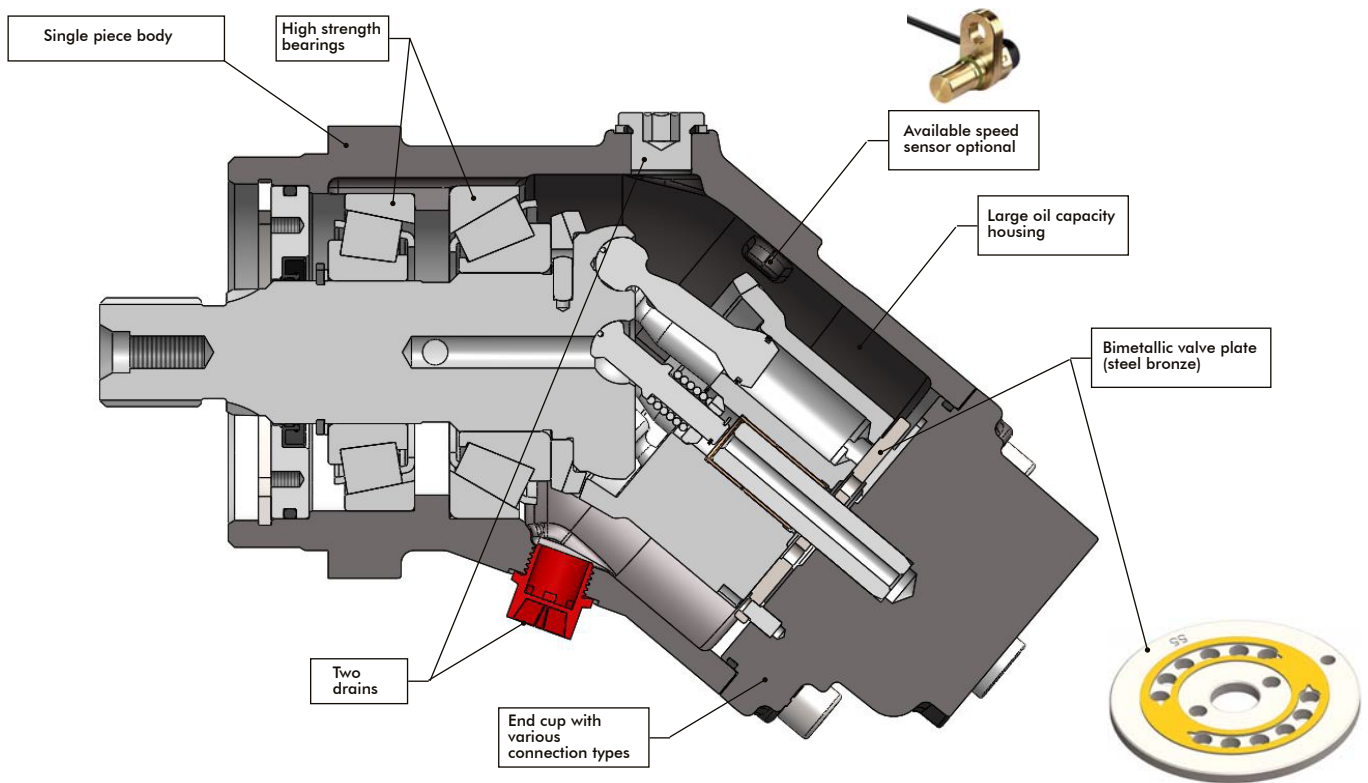

HPM3 MOTORS - 3 PARTS

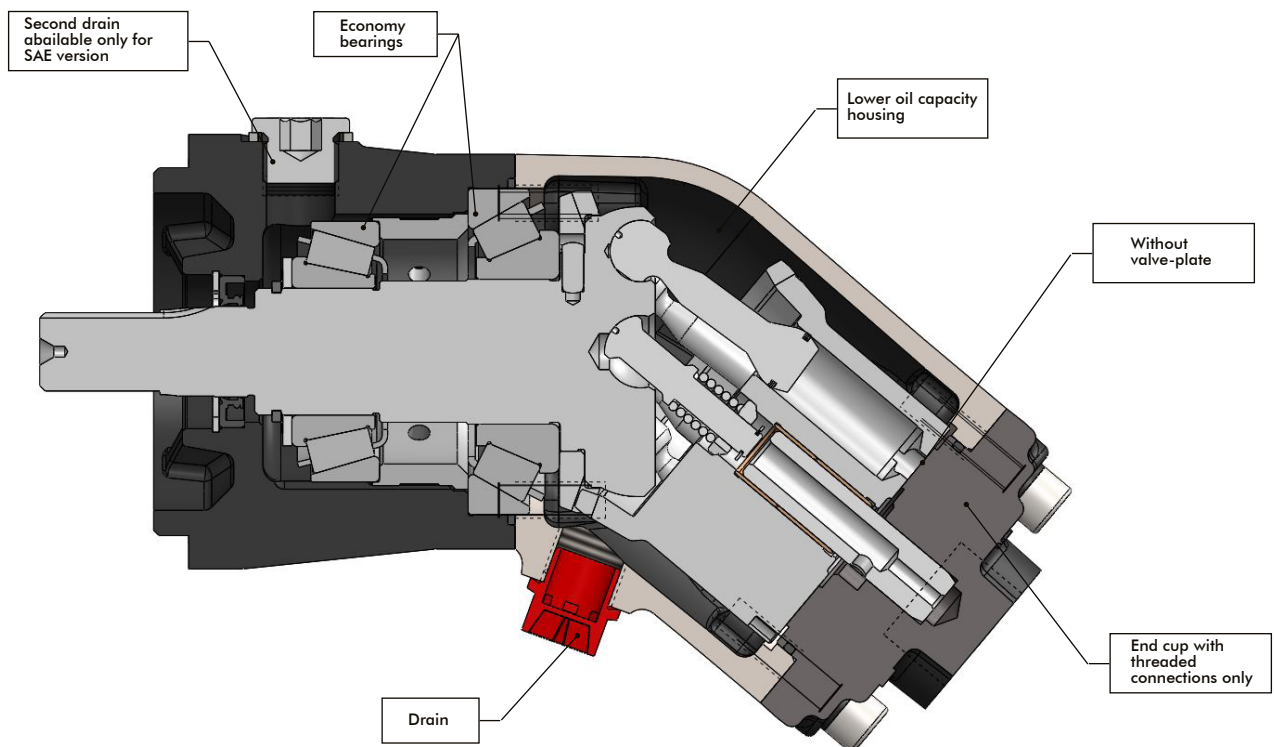

HPM 12 - MECCANICAL EFFICIENCY

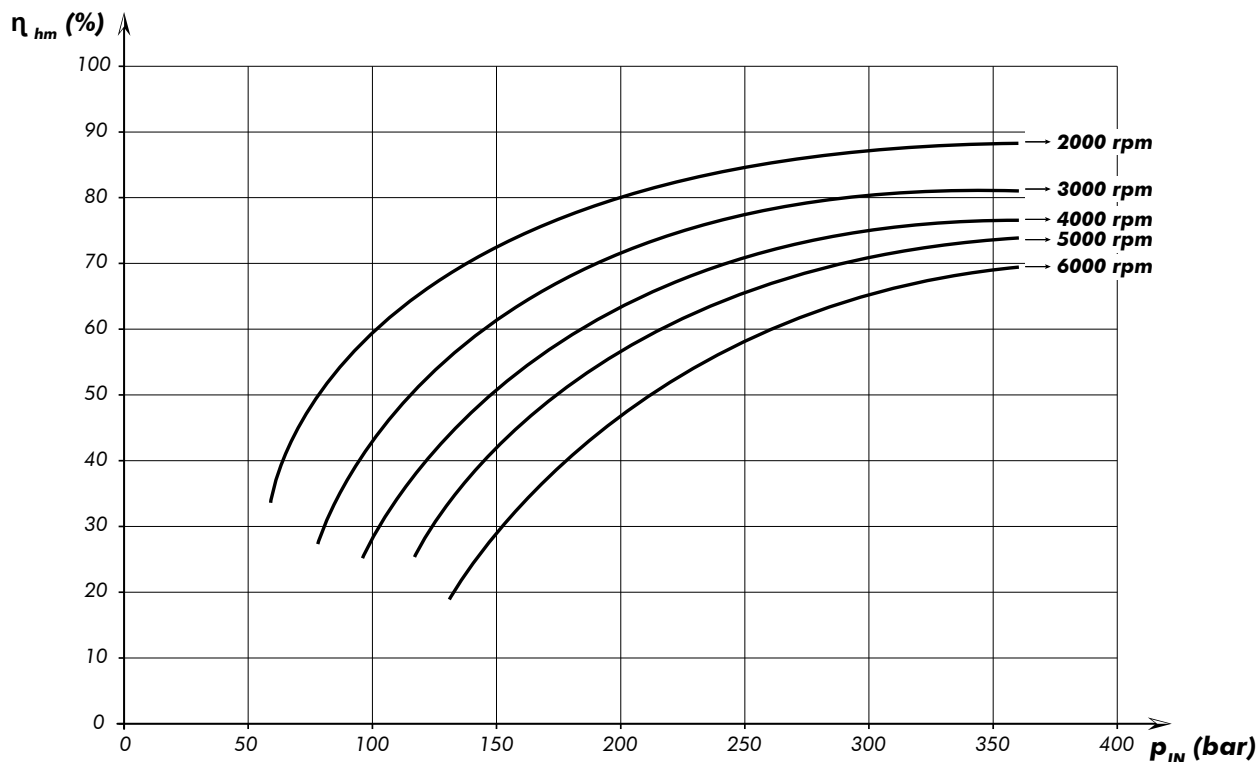

HPM 12 - VOLUMETRIC EFFICIENCY

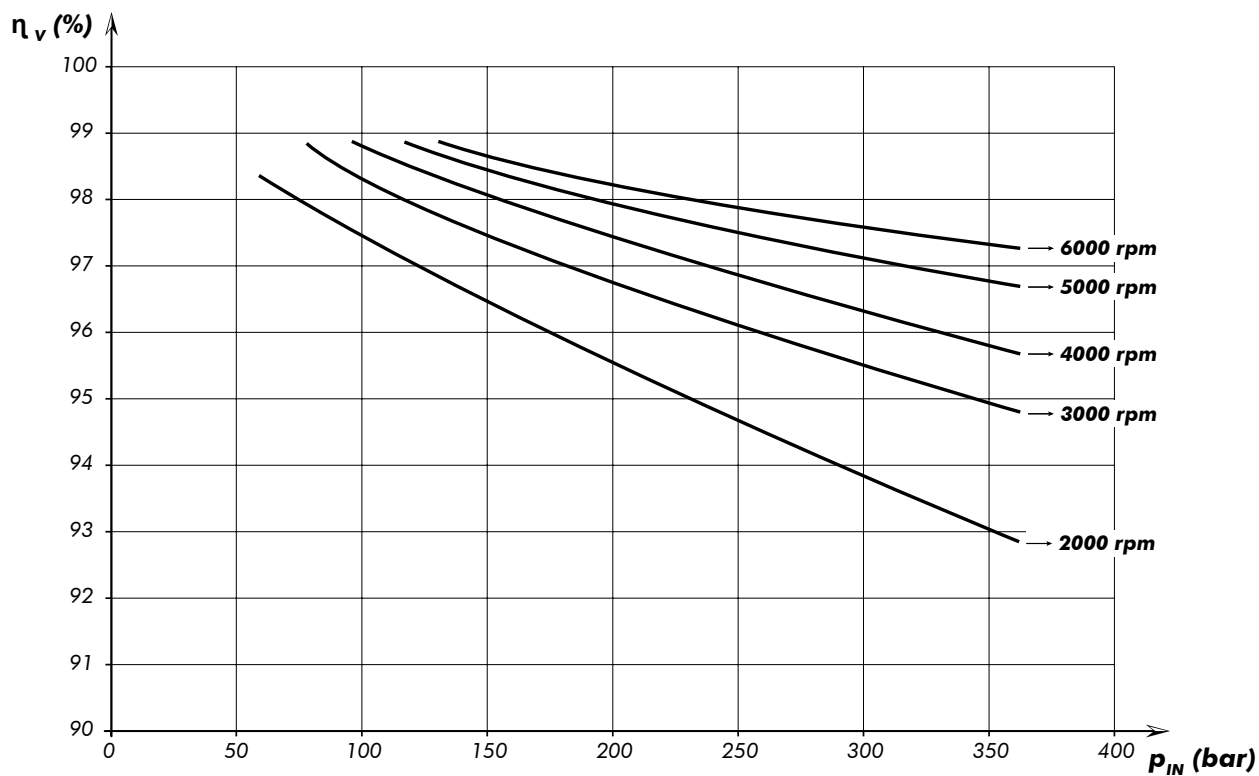

HPM 17 - MECCANICAL EFFICIENCY

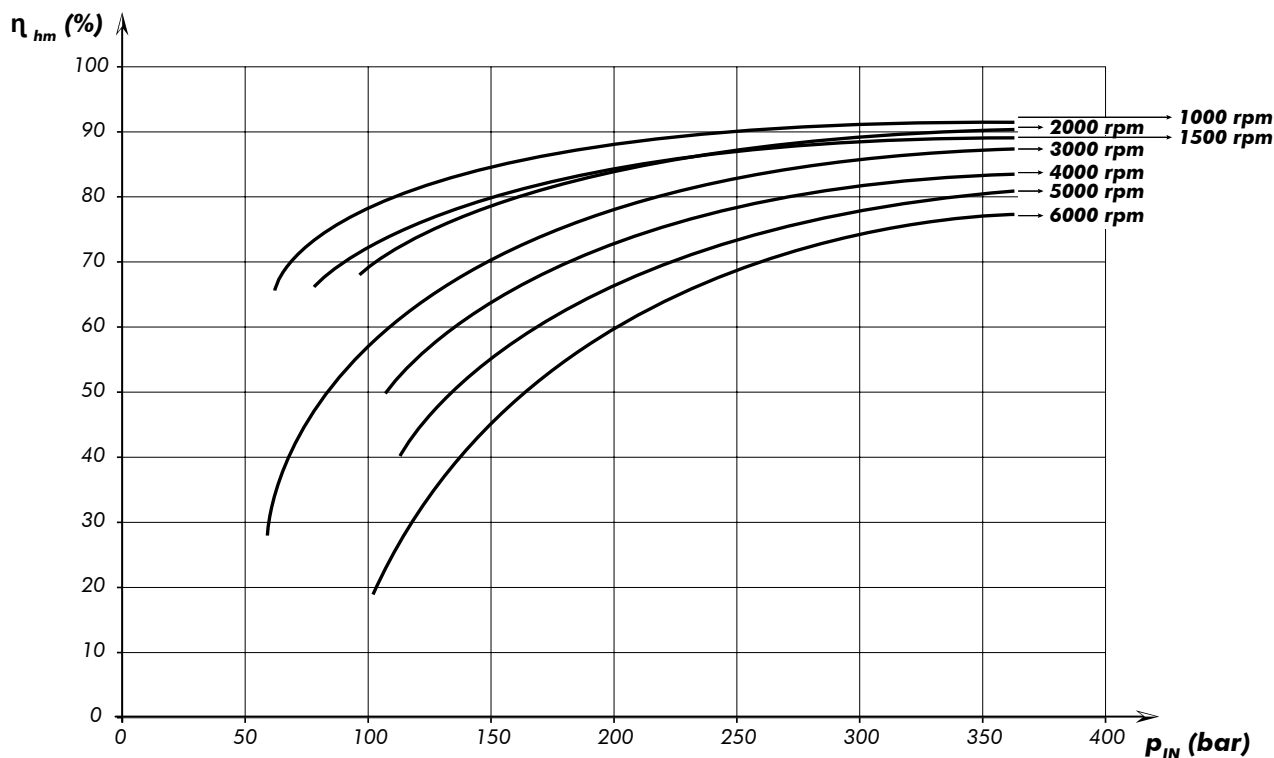

HPM 17 - VOLUMETRIC EFFICIENCY

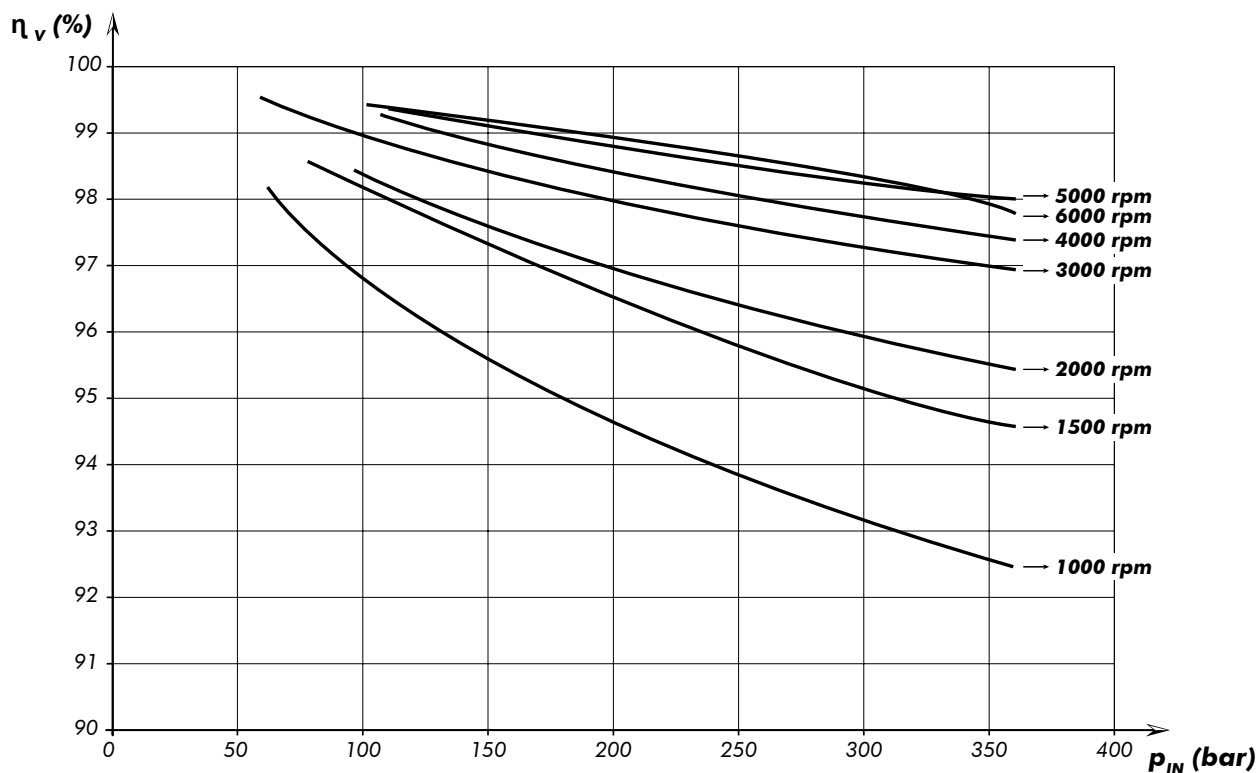

Codice fascicolo:997-400-24411

Data: Venerdì 28 settembre 2018

Rev: AL

Codice foglio:997-244-00011

HPM 34 - MECCANICAL EFFICIENCY

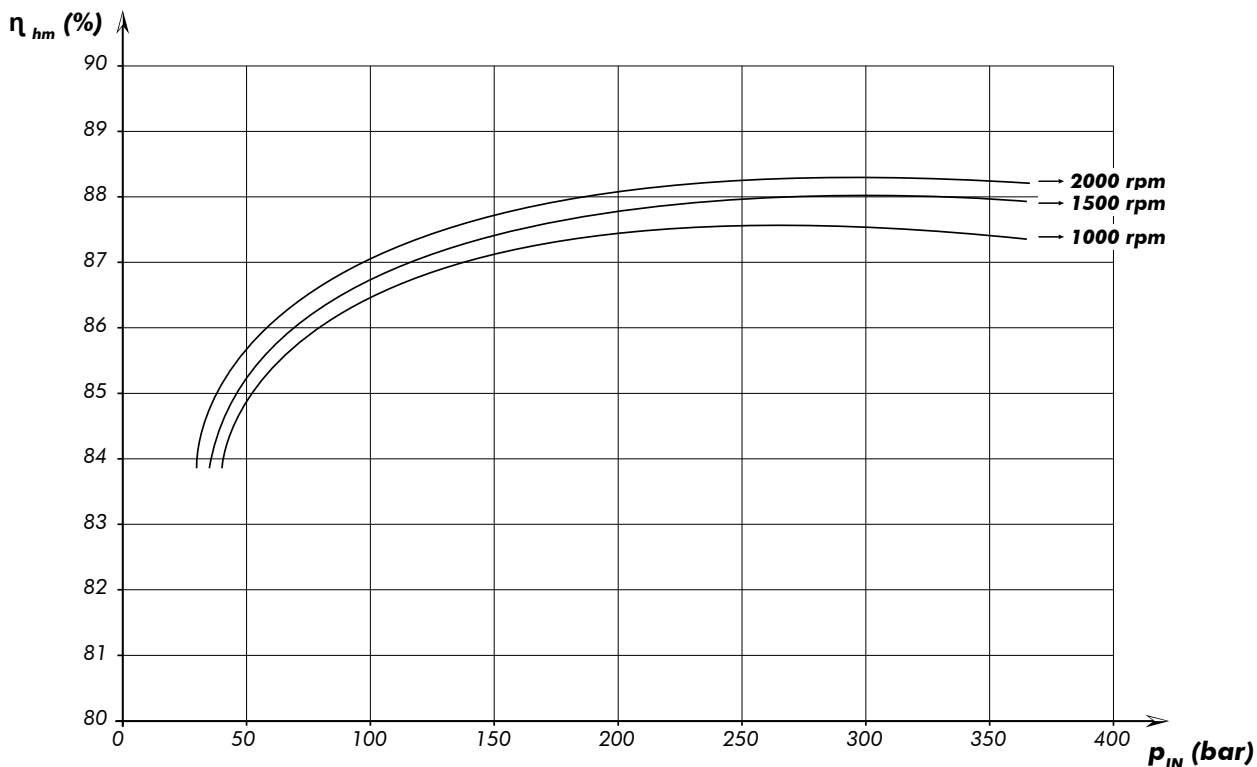

HPM 34 - VOLUMETRIC EFFICIENCY

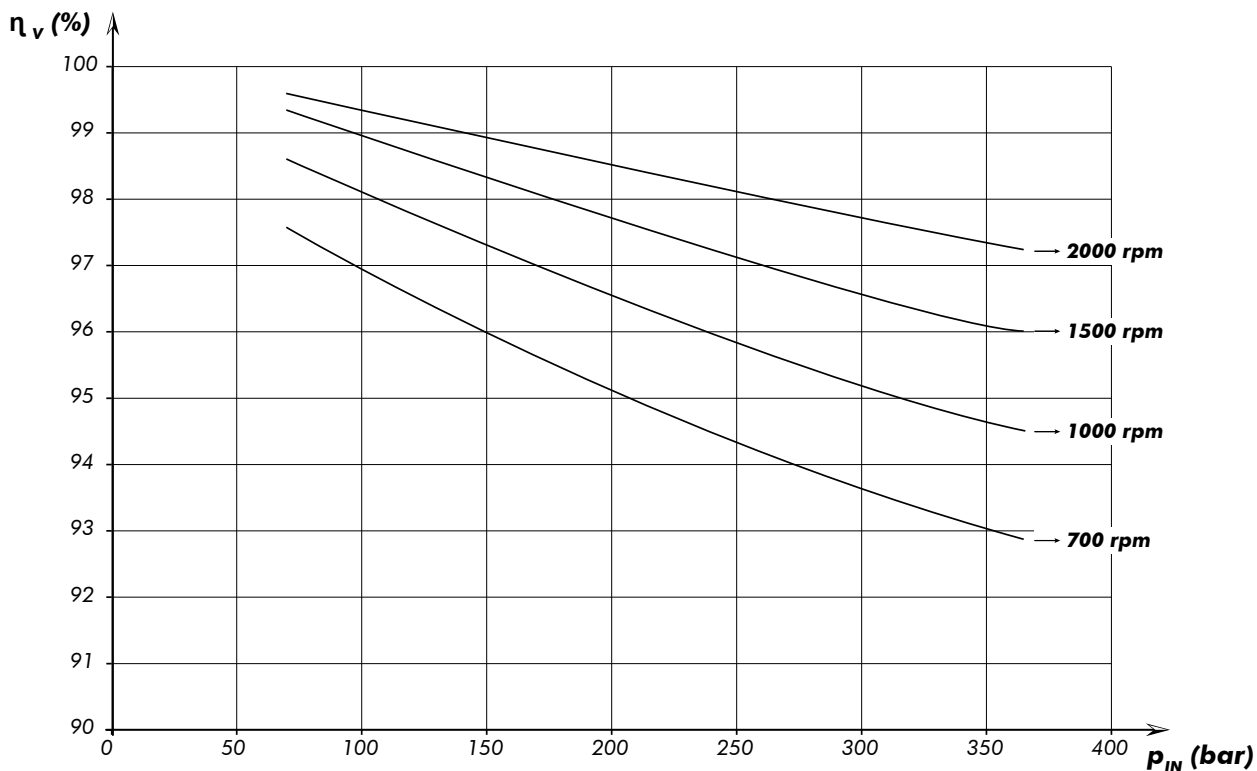

HPM 40 - MECCANICAL EFFICIENCY

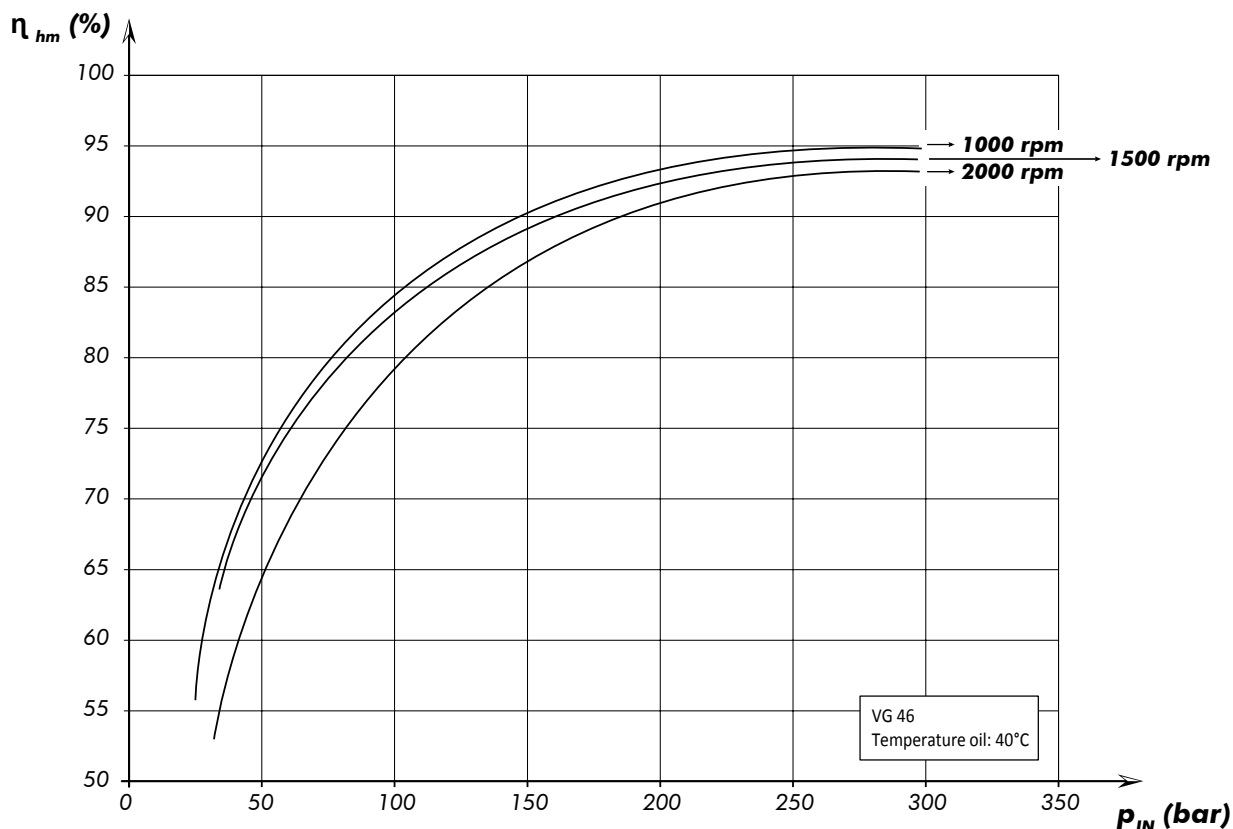

HPM 40 - VOLUMETRIC EFFICIENCY

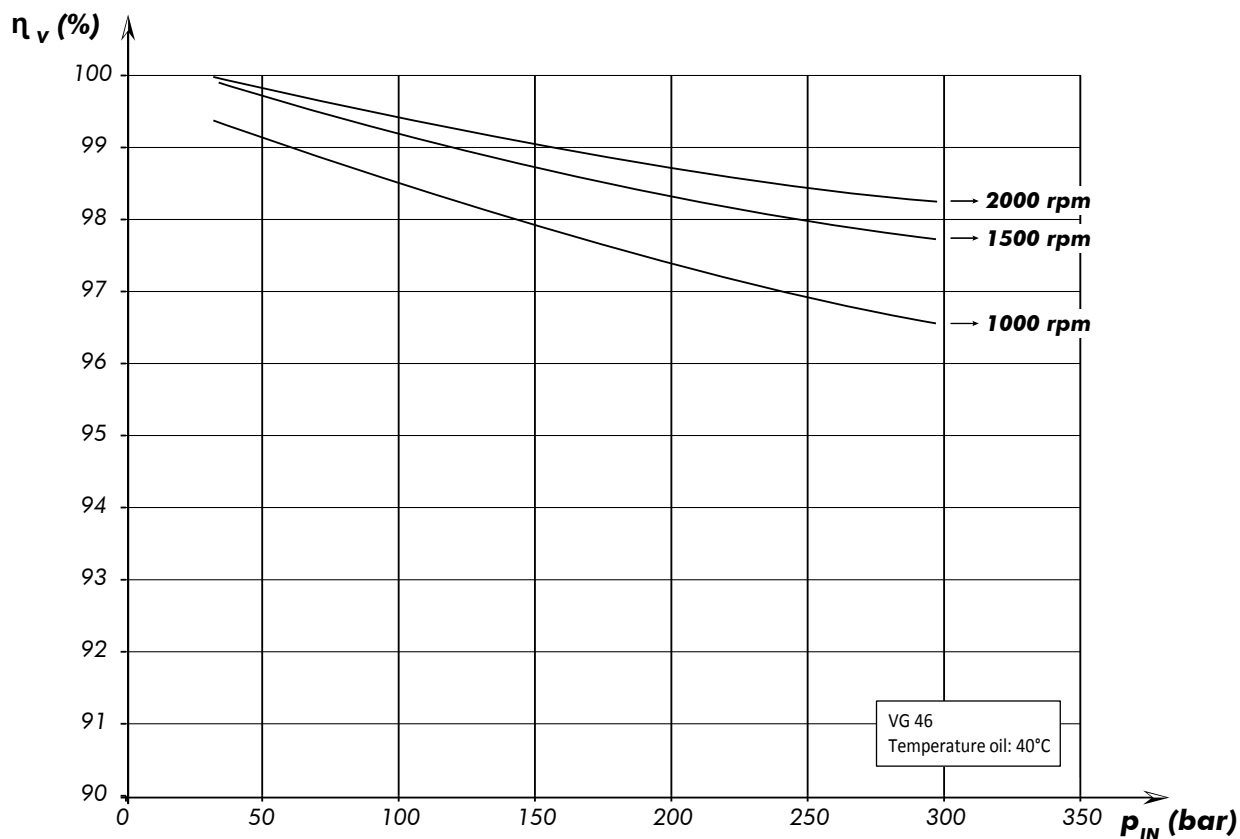

Codice fascicolo: 997-400-24411

Data: Venerdì 28 settembre 2018

Rev: AL

Codice foglio: 997-244-00011

DIAGRAMS

HPM 47 - MECCANICAL EFFICIENCY

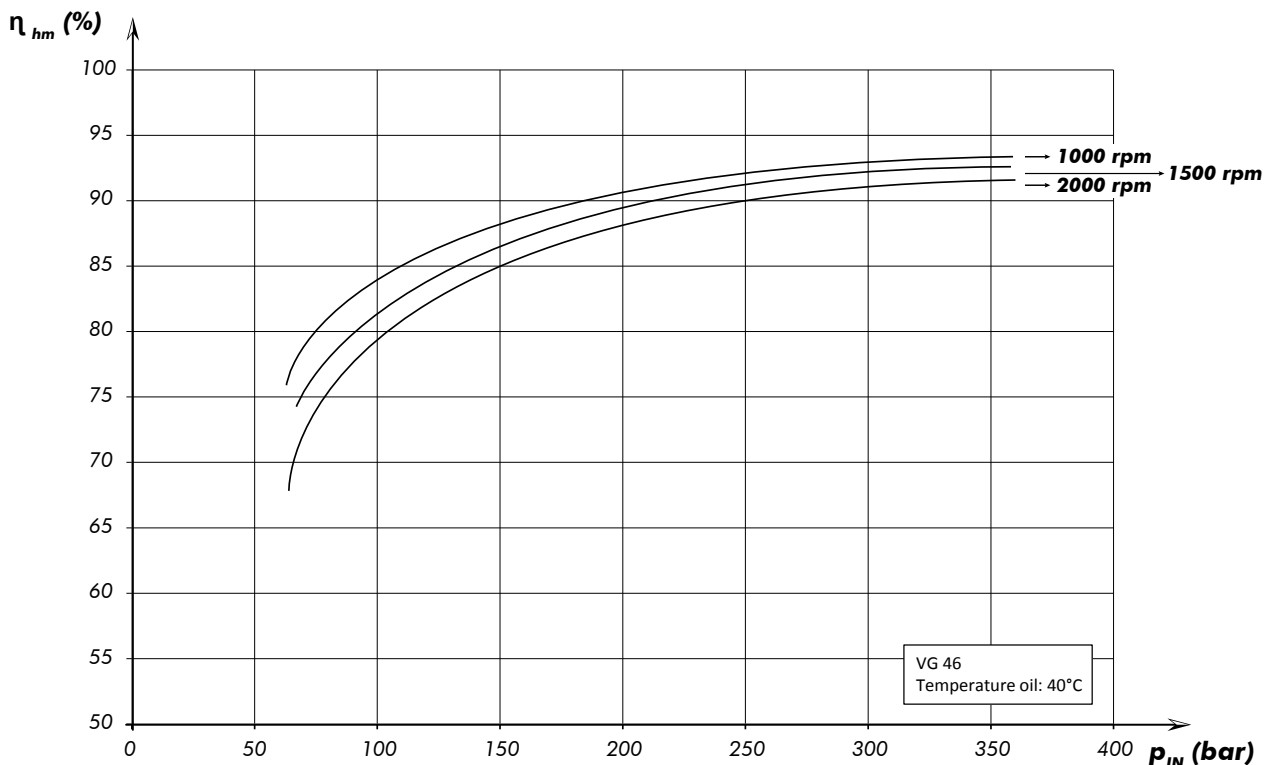

HPM 47 - VOLUMETRIC EFFICIENCY

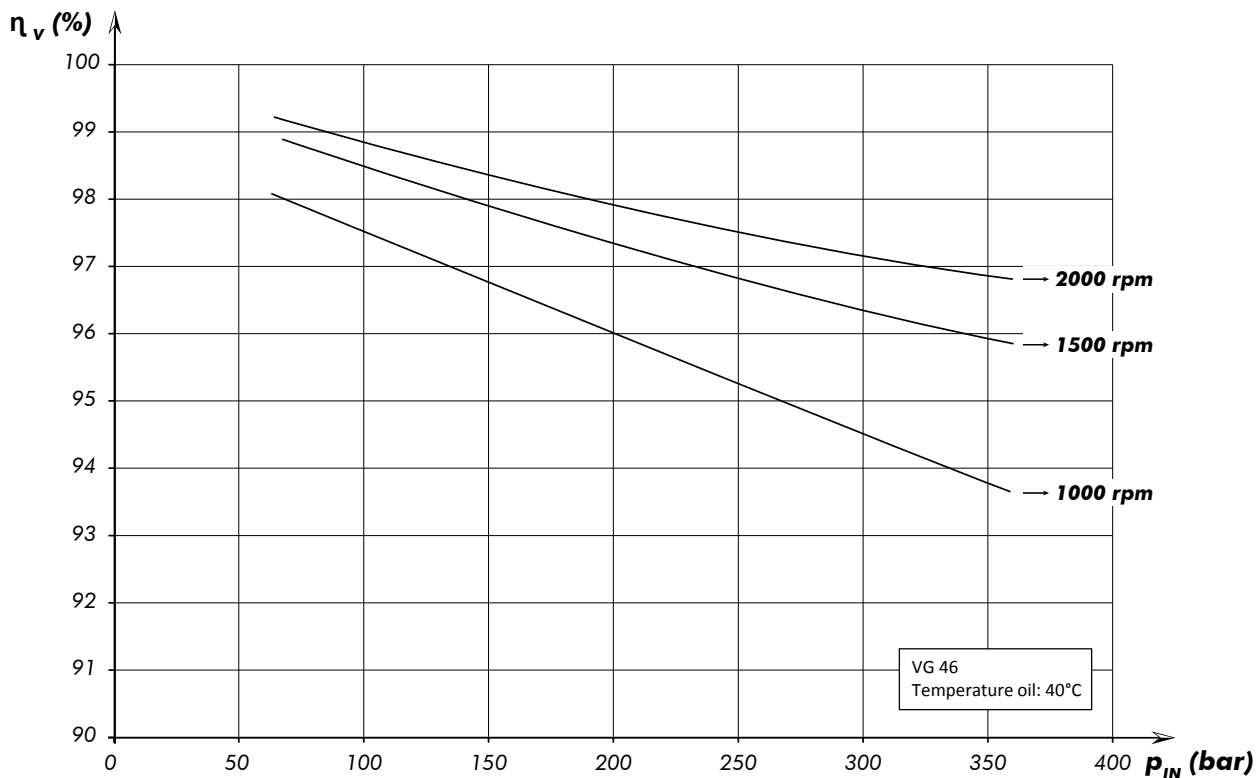

HPM 55 - MECCANICAL EFFICIENCY

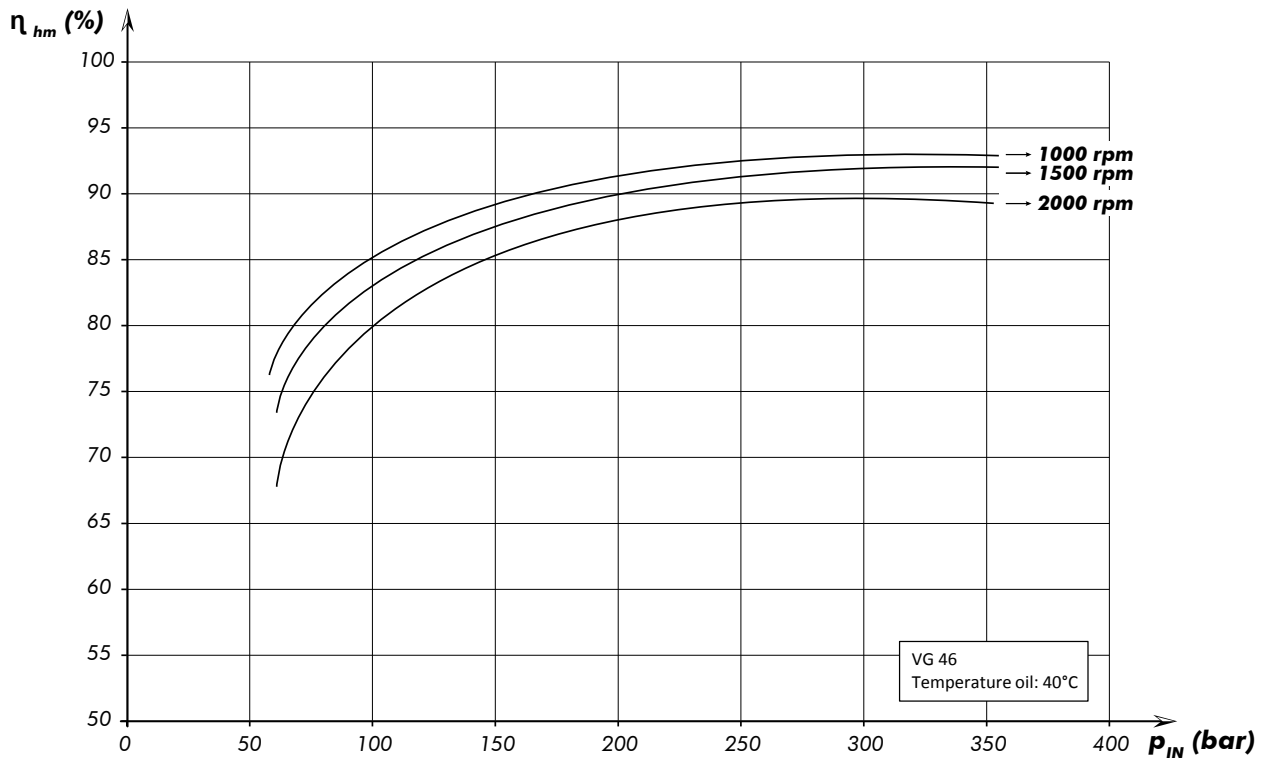

HPM 55 - VOLUMETRIC EFFICIENCY

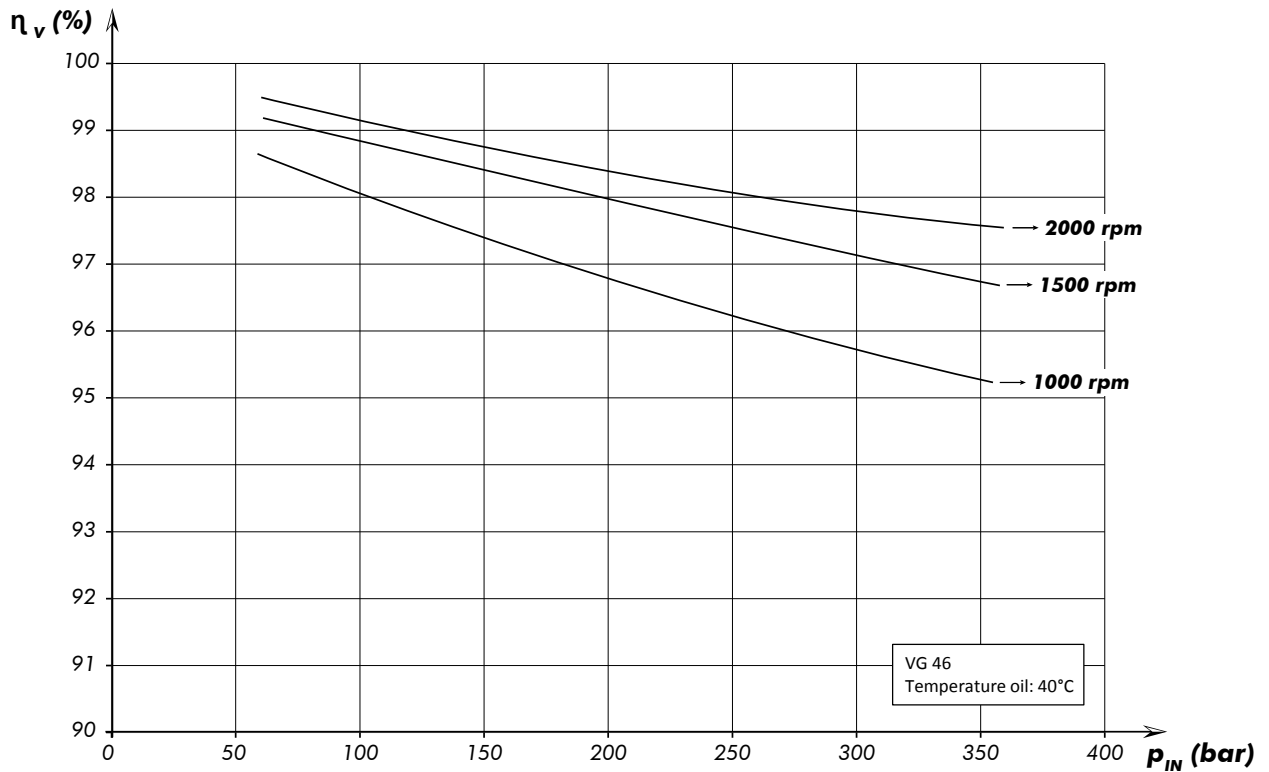

Codice fascicolo:997-400-24411

Data: Venerdì 28 settembre 2018

Rev: AL

Codice foglio:997-244-00011

DIAGRAMS

HPM 64 - MECCANICAL EFFICIENCY

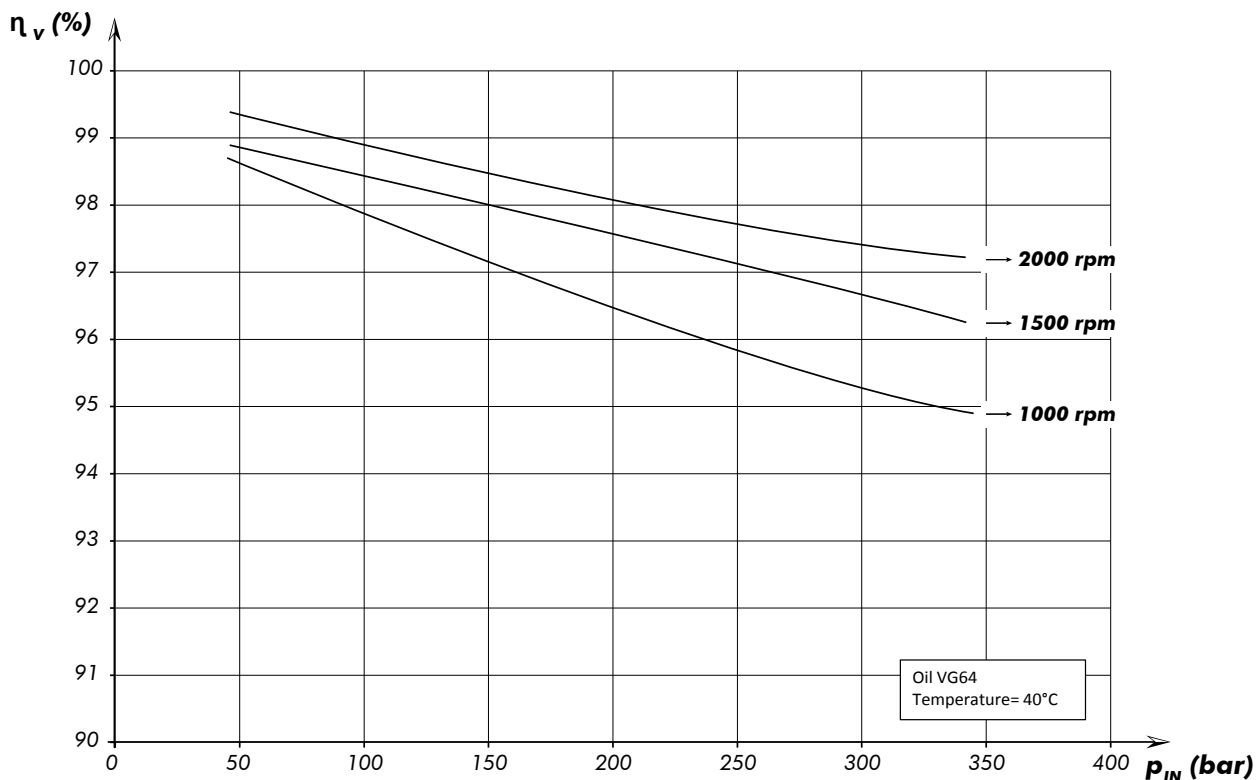

HPM 64 - VOLUMETRIC EFFICIENCY

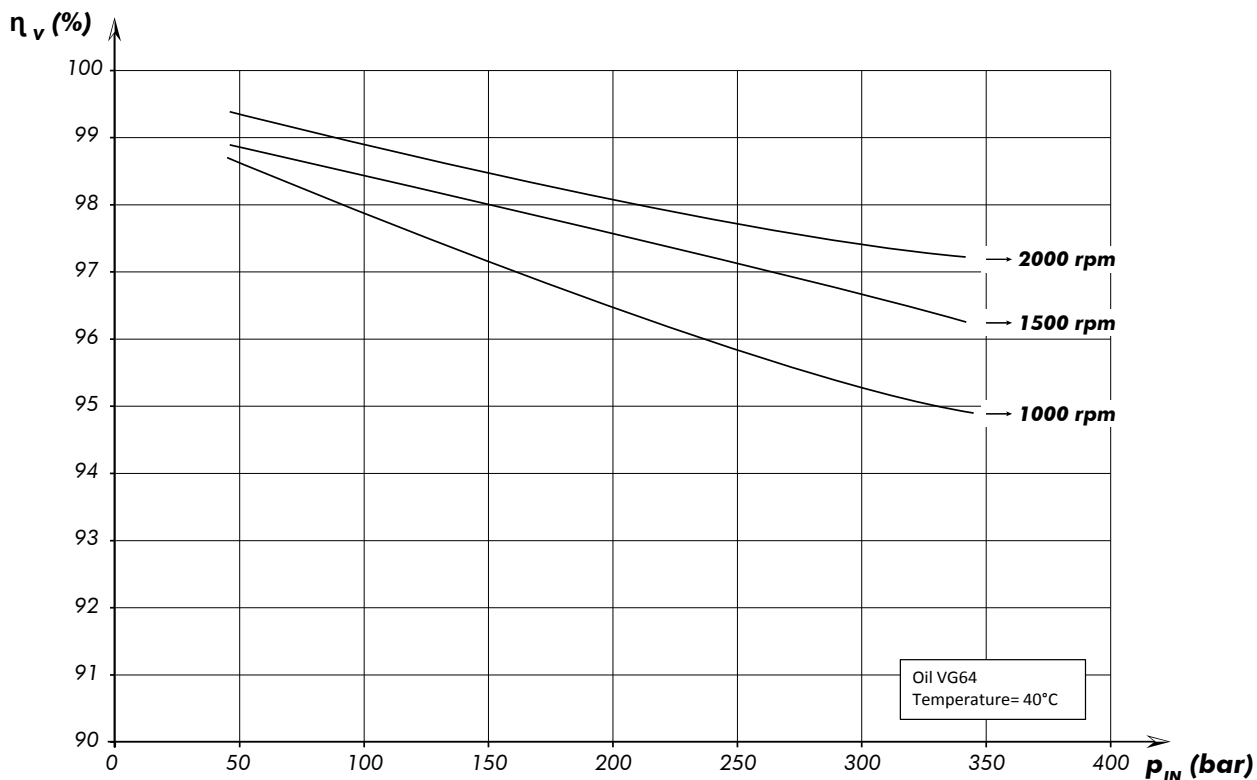

HPM 80 - MECCANICAL EFFICIENCY

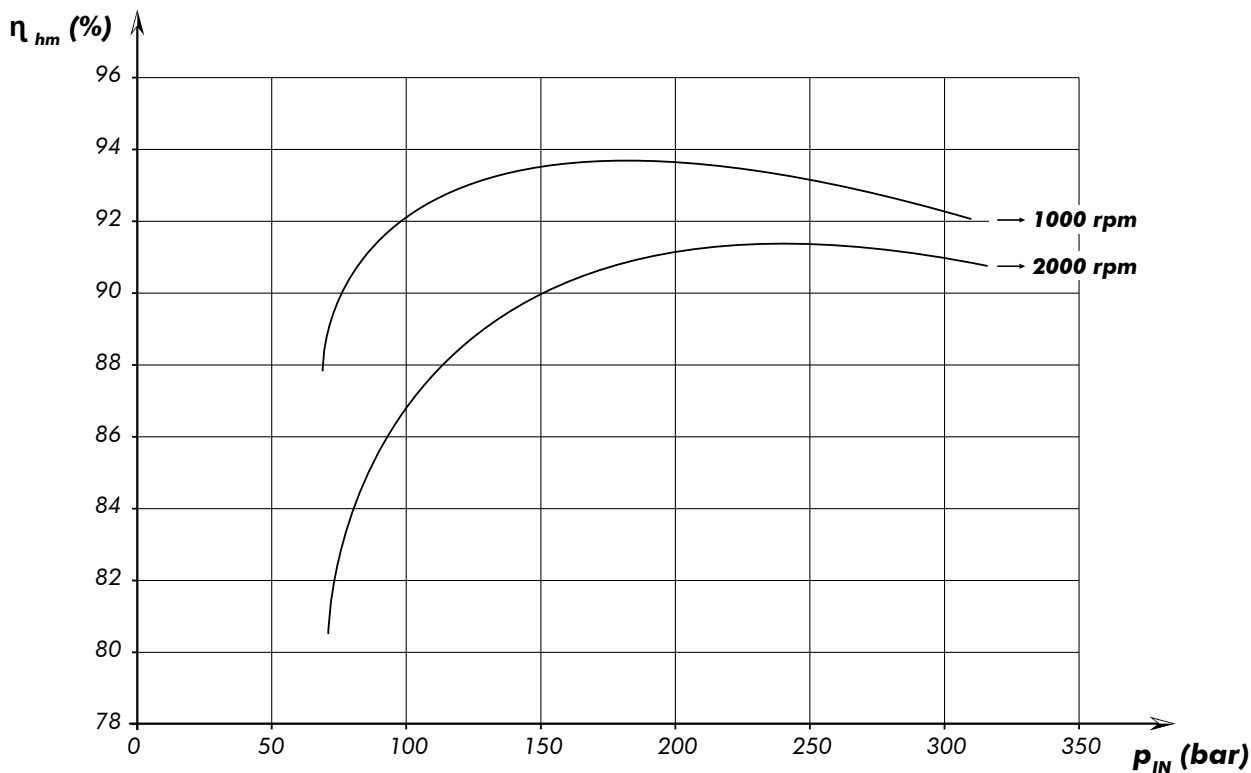

HPM 80 - VOLUMETRIC EFFICIENCY

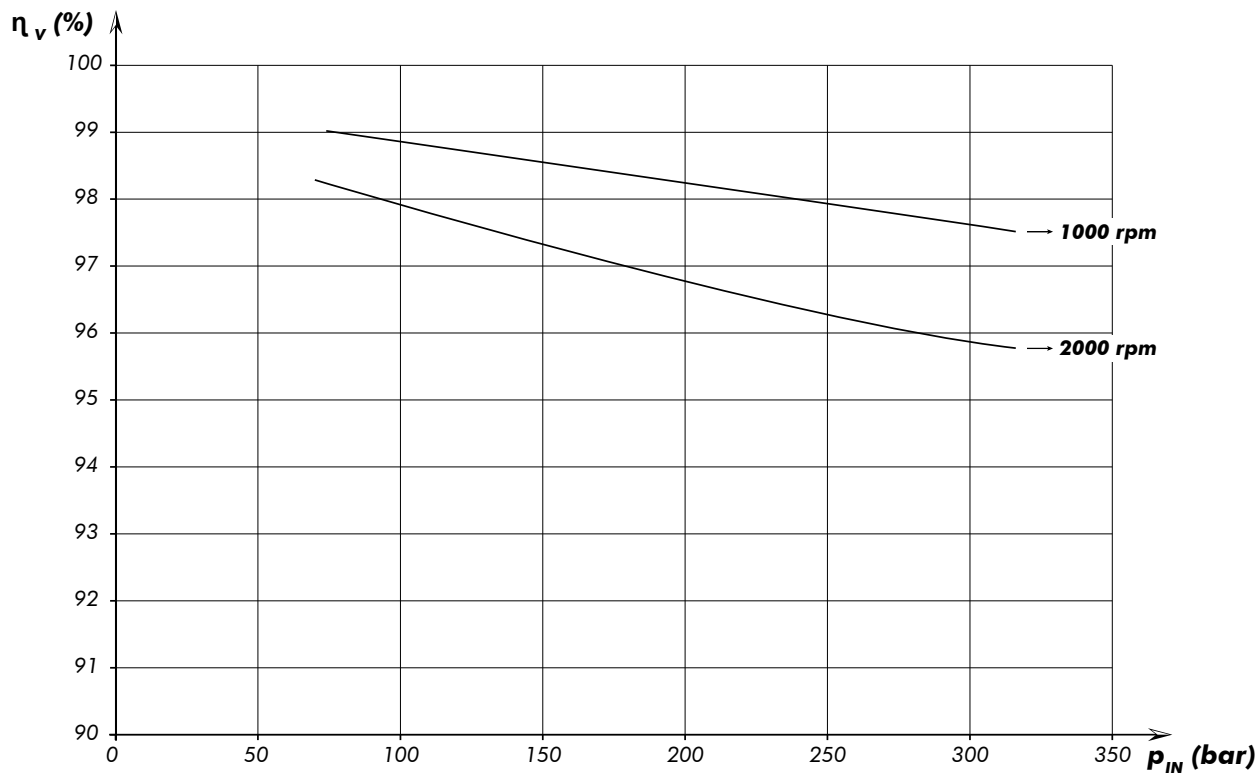

Codice fascicolo:997-400-24411

Data: Venerdì 28 settembre 2018

Rev: AL

Codice foglio:997-244-00011

TECHNICAL FEATURES

BENT AXIS PISTON MOTORS SERIES "HPM" FLANGE ISO 3019--

		TECHNICAL FEATURES														
Displacement	cm ³ /rev	12	17	25	34	40	47	55	64	80	91	108	130			
Working pressure	bar	Max. intermittent	400													
		Max. continuous	350													
Rotation speed	rpm	Max. intermittent	6800				5500				4500					
		Max. continuous	6300				5000				4000					
		Min. continuous	100													
Power	kW	Max. intermittent	54	77	113	154	172	202	235	240	270	324	390			
		Max. continuous	18	26	38	51	49	57	67	78	80	90	108	130		
Torque	Nm/bar	0,26	0,33	0,43	0,56	0,63	0,7	0,83	0,97	1,3	1,43	1,6	1,8			
Mass inertial moment (x 10 ⁻⁴)	kg m ²	11,5			12,5			35,5			61					
Max. pressure in the housing	bar	20														
Weight (ISO 3019-2 flange)	kg	8,5			11,5			20			30,5			38,5		
Weight (ISO 3019-1 SAE B flange)		10			12			---			---			---		
Weight (ISO 3019-1 SAE C flange)		---			---			20			---			---		

ATTENTION ! in some cases Working Pressure is limited by shaft's dimensions. Check on each motor's dedicated data sheet, in the section dedicated to shafts, if a table with modified working pressure values is indicated. If not, consider values shown above.

SHAFT LOADS

The lifetime of the motor depends on how the bearings are working. Operational parameters such as speed, pressure, oil viscosity and grade of cleanness when are dimensioned and applied correctly can guarantee a longer lifetime to the motor along with higher performances and reduced noise level. Also external factors such as dimensions, weight and position of the external load on the shaft can influence the lifetime of the bearings. For different conditions and/or check of your working conditions please contact our technical/sales department.

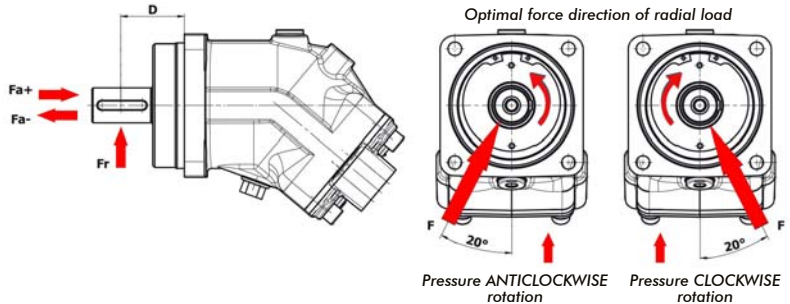

HPM MOTORS FLANGE ISO 3019-2 (Fam. 240-242-244-246-248)		DISPLACEMENT											
MAX RECOMMENDED SHAFT LOADS		12	17	25	34	40	47	55	64	80	91	108	130
Fr (radial) max	kN	7	5	7	6	9			14,5	12	14,5	12	
Distance D (to point of force)	mm	40		50		62			67		80		
Fa (axial) + (at standstill/ 0 bar pressure) max	kN	3		3		4			5		5		
Fa (axial) - (at standstill/ 0 bar pressure) max	kN	4	5	7		7	10	11	13	14	16	19	
Fa (axial) + (at 350 bar pressure) max *	kN	6	8	10,8	12	16	20	20	13	14	16	19	
Fa (axial) - (at 350 bar pressure) max *	kN	1,2	2,08		2,8		3,5		4	4,5	4,5	5,5	

HPM MOTORS FLANGE ISO 3019-1 (Fam. 221-224)		DISPLACEMENT							
MAX RECOMMENDED SHAFT LOADS		12	17	25	34	40	47	55	64
Fr (radial) max	kN	7	5	7	6	9			
Distance D (to point of force)	mm	28		32		38			
Fa (axial) + (at standstill/ 0 bar pressure) max	kN	3		3		4			
Fa (axial) - (at standstill/ 0 bar pressure) max	kN	4	5	7		7	10	11	
Fa (axial) + (at 350 bar pressure) max *	kN	6	8	10,8	12	16	20		
Fa (axial) - (at 350 bar pressure) max *	kN	1,2	2,08		2,8		3,5		

* Fa (axial) + Will increase bearing life

* Fa (axial) - Will decrease bearing life

HOSE SIZING

The recommended flow of the delivery hose should not exceed a fluid maximum speed of 5m/s.

FILTRATION

We recommend a cleanness grade according to ISO 4406-1999

- code 19/17/14 up to 140 bar.
- code 18/16/13 from 140 bar to 200 bar.
- code 17/15/12 over 200 bar.

SERIES CONNECTION OF HPM MOTORS

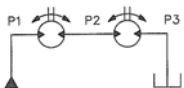

The maximum allowed pressure on the ports is 350 bar continuous and 400 bar intermittent. In case of series connection we recommend to limit the total working pressure P1+P2 always to 350 bar continuous and 400 bar intermittent.

Thread	Max. fittings tightening torque
M10 x 1	50 Nm
M12 x 1,5	80 Nm
G 1/2	80 Nm
G 3/4	100-120 Nm
G 1	180-200 Nm
G 1-1/4	310-330 Nm

MAX. PRESSURE

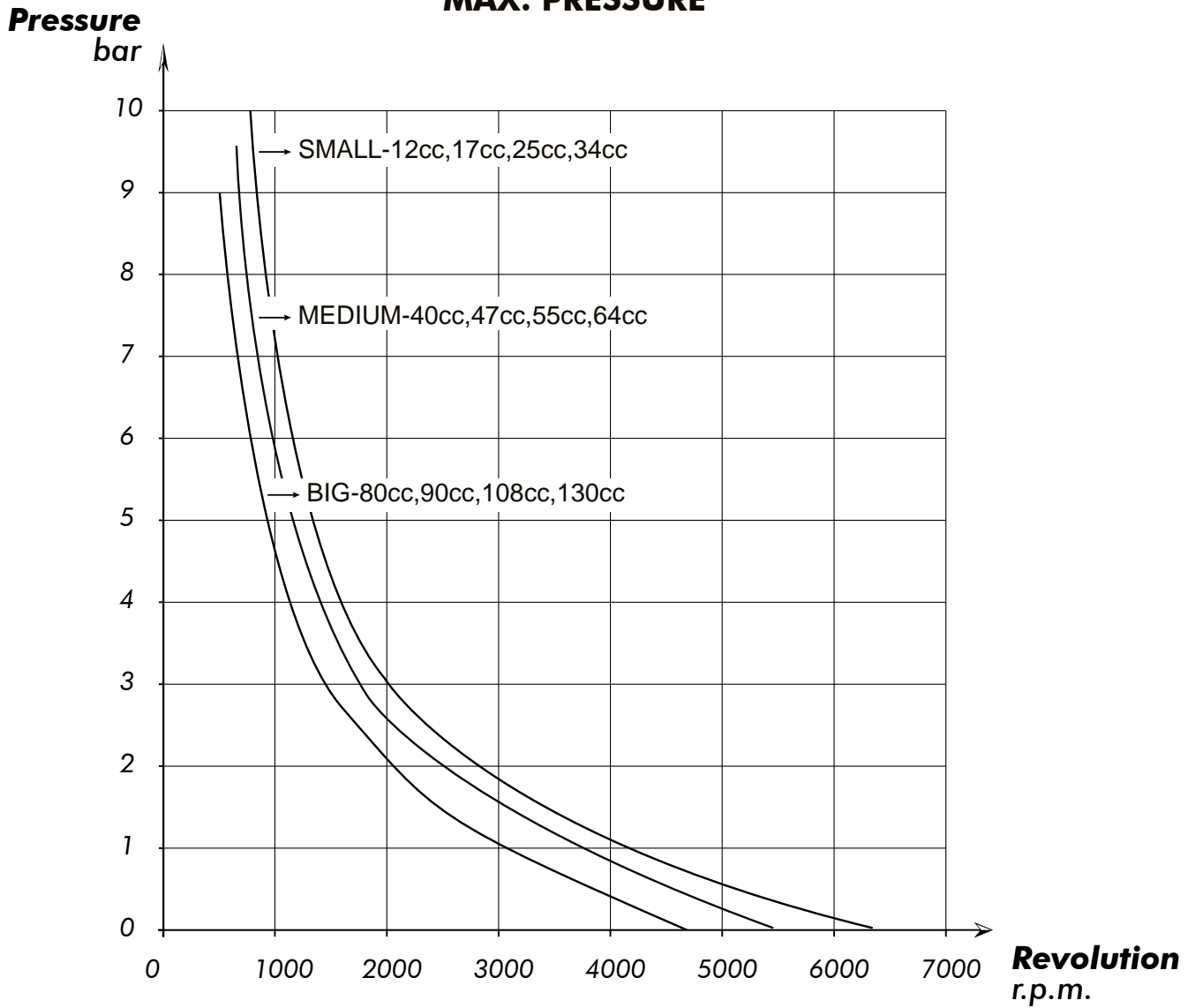

Codice fascicolo:997-400-24411

Data: Venerdì 28 settembre 2018

Rev: AL

Codice foglio:997-244-00011

TECHNICAL FEATURES

TEMPERATURE/COOLING OF MOTOR CASING

High oil temperature reduces the lifetime of shaft oil seal and can lower the oil viscosity below the recommended level. The temperature of the system shall not exceed 60°C while temperature of return line shall not exceed 90°C.
Cooling/flushing of motor casing might be necessary to keep return temperature within the recommended level.

MOTOR	FLUSHING	CONT.
12-34	2-8 l/min.	≥ 2800 rev/min.
40-64	4-10 l/min.	≥ 2500 rev/min.
80-130	6-12 l/min.	> 2200 rev/min.

Reference value for motor casing flushing.

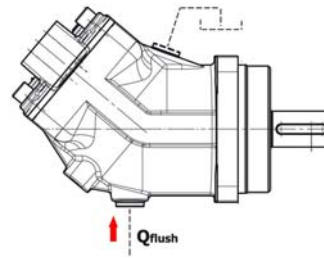

The motor casing flushing can be achieved by means of a flushing valve or directly from the return hose. Too low return pressure must be compensated by a back-pressure valve. The tank hose must be connected into the highest point as shown in the picture.

TYPES OF FLUID

The table below shows the main types of hydraulic fluid as set out in ISO 6743-4 standard.

- HL RECOMMENDED

(For other type of fluid please contact our sales/technical dept).

Mineral oil-based fluids	
HH	Additive-free
HL	Anticorrosive, antioxidant (RECOMMENDED)
HM	HL and anti-wear additives
HV	HM additives and viscosity controls
Flame-resitant fluids	
HFA	Oil-based emulsion in water (water > 90%)
HFB	Water-based emulsion in oil (water > 40%)
HFC	Water in glycol solution (polyhydrate alcohols)
HFD	Water-free synthetic fluids (phosphoric esters)
Organic fluids	
HETG	Vegetable-based fluids
HEPG	Synthetic polyglycol-based fluids
HEE	Synthetic ester-based fluids

VISCOSITY INDEX

The optimum viscosity of the fluid V_{opt} at the operating temperature (temperature of the tank for open circuits or temperature of the circuit for closed circuits) must fall between the minimum and maximum values shown in the table below. The minimum viscosity V_{min} shown in the table is permitted in extreme conditions and for short periods. This value refers to a maximum fluid temperature of 90°C (temperature of drainage fluid). The maximum viscosity V_{max} for short intervals and during cold starts is shown in the table below. The temperature of the fluid must never exceed a maximum of +90°C and a minimum of -25°C.

	V_{opt} (cSt)	V_{min} (cSt)	V_{max} (cSt)
HPM	15+40	10	800

VISCOSITY GRADES

Under the ISO standard, hydraulic fluids are divided into 6 grades of viscosity (see table below). Viscosity grades are shown by the letters VG followed by the viscosity of the fluid in cSt at a temperature of 40 °C.

VISCOSITY GRADES ISO	V (40°) (cSt)
VG 10	9÷11
VG 22	19.8÷24.2
VG 32	28.8÷35.2
VG 46	41.4÷50.6
VG 68	61.2÷71.5
VG 188	90÷110

In order to choose the correct type of fluid, it is essential to know the operating temperature of the fluid (temperature of the tank for open circuits or temperature of the circuit for closed circuits) and its viscosity index. At the operating temperature, the viscosity of the fluid must fall within the optimum viscosity values (V_{opt}). The diagram below shows the variations of viscosity at various temperatures of a class of fluids sharing the same viscosity index.

Viscosity - temperature diagram*

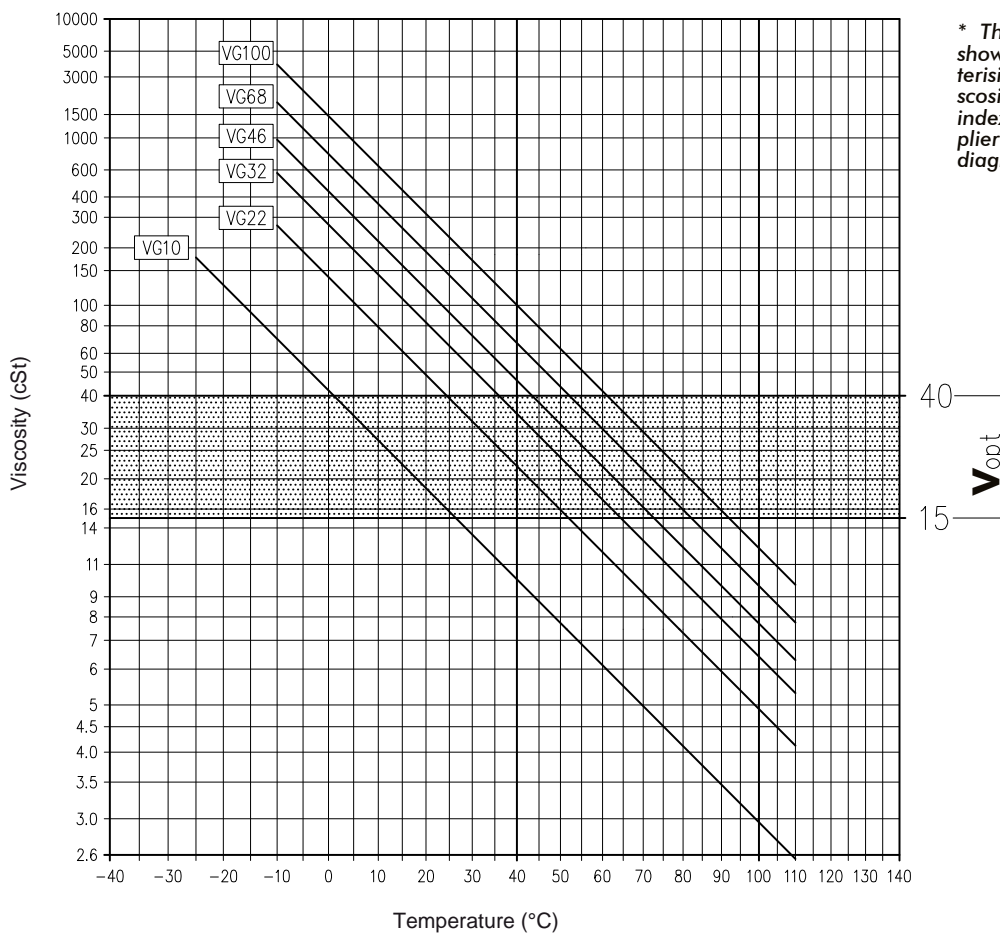

* The diagram is only an example. It shows the viscosity temperature characteristics of typical fluids with different viscosities but sharing the same viscosity index. Ask to your hydraulic fluid supplier for the real viscosity-temperature diagram of the fluid used in your system.

TECHNICAL FEATURES

PRELIMINARY OPERATION



Before to start up the motor please fill-up the the casing with oil.
We recommend the highest level of cleanness during the operations of oil filling-up and change.
Plugs tightening torque: 20-25 Nm

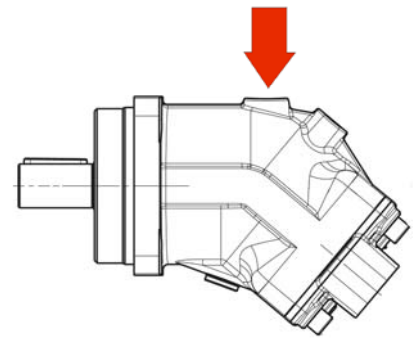

Connect the drain line before using the motor.

Use always the upper drain port according to the motor position and in any case always use the drain port that can ensure the casing being filled-up.

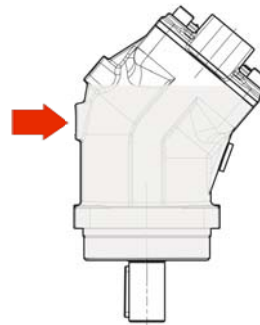
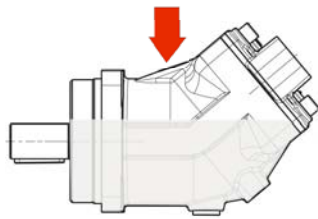
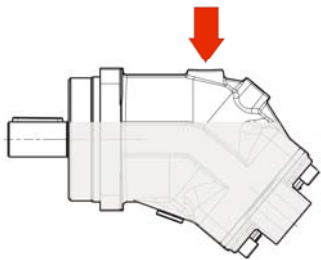

for other installations,
contact manufacturer.

The direction of rotation of the motor depends from direction of delivery oil as shown in the picture below. Make sure about the correct sizing and positioning of the oil hoses. Insufficient diameter, kinks and/or tight elbows may lead to cavitation and consequently further damages and high noise level.

CLOCKWISE
rotation

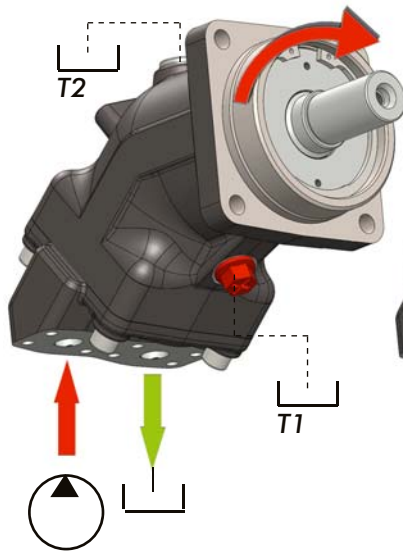

ANTICLOCKWISE
rotation

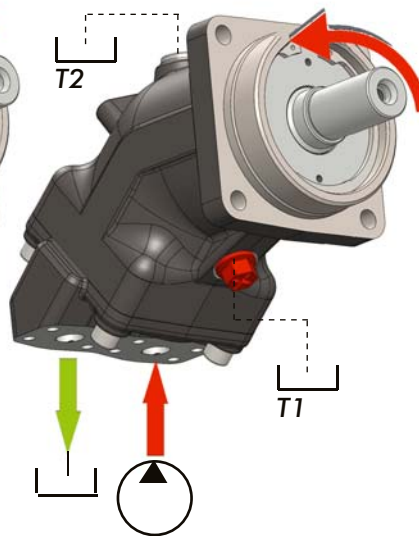

It is essential to drain the motor (T1 or T2) to relief the shaft seal from excessive pressure. The maximum internal pressure allowed depends on the rotating speed of the motor. However, we can take into consideration the following values:

- Max internal pressure independent from the rotating speed (continue): 4 bar.
- Max internal pressure independent from the rotating speed (peak): 5.5 bar.

FORMULAS FOR MOTORS

INPUT HYDRAULIC POWER

In a motor the input hydraulic power is proportional to the pressure difference between the ports and to the flow according to the ratio where

P_i is the hydraulic power in kW

Q is the flow in l/min

Δp is the pressure difference in bar between the ports

$$P_i = \frac{Q \cdot \Delta p}{600}$$

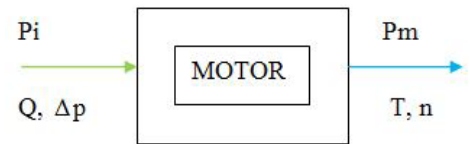

MECHANICAL POWER TO THE SHAFT

In a motor the mechanical power available is proportional to the torque at the shaft and to the angular speed of the shaft according to the ratio where

P_m is the mechanical power in kW

T is the torque in Nm

n is the rpm

$$P_m = \frac{T \cdot n}{9550}$$

INPUT FLOW FOR ROTATING THE SHAFT AT SPEED n

where:

Q is the flow in l/min

n is the rpm

c is the displacement of the motor in cc/rev

η_v is the volumetric efficiency of the motor

$$Q = \frac{n \cdot c}{1000 \cdot \eta_v}$$

MOTOR SPEED WHEN IN INPUT YOU HAVE FLOW Q

where

Q is the flow in l/min

n is the rpm

c is the displacement of the motor in cc/rev

η_v is the volumetric efficiency of the motor

$$n = 1000 \cdot \frac{Q}{c} \cdot \eta_v$$

TORQUE TO THE SHAFT WITH A PRESSURE DIFFERENCE p BETWEEN THE PORTS

where

T is the torque in Nm

c is the displacement of the motor in cc/rev

Δp is the pressure difference in bar between the ports

η_m is the mechanical efficiency of the motor

$$T = \frac{c \cdot \Delta p}{62.8} \eta_m$$

PRESSURE DIFFERENCE REQUIRED BETWEEN INPUT PORTS TO OBTAIN TORQUE T AT THE SHAFT

where

Δp is the pressure difference in bar between the ports

T is the torque in Nm

c is the displacement of the motor in cc/rev

η_m is the mechanical efficiency of the motor

$$\Delta p = 62.8 \cdot \frac{T}{c \cdot \eta_m}$$

BENT AXIS PISTON MOTORS SERIES "HPM" FLANGE ISO 3019-2

FLANGE Ø 80

HPM



SAE FLANGE	ISO FLANGE mm	DISPLACEMENT cm ³	VALVES OFFSET mm	Z (THEET) n°	SENSOR DEPTH mm
SAE B	Ø80	12-17	42	27	18,4
	Ø100	25-34	59		
SAE C	Ø125	40-47 55-64	75	32	
	Ø140	80-91	84	38	
	Ø160	108-130	99		32

P	Motor with speed sensor option
M	Motor complete with selected speed sensor already mounted

(see page 51)

VERSIONS CODING

FLANGE TYPE

--	--	--

SHAFT

--	--	--

REAR COVER & PORTINGS

--	--

DISPLACEMENT

--	--	--

VARIANTS

--

Flange type	OMFB code
ISO 3019-2 4H ø 80 LONG	240
ISO 3019-2 4H ø100 LONG	242
ISO 3019-2 4H ø125 LONG	244
ISO 3019-2 4H ø140 LONG	246
ISO 3019-2 4H ø160 LONG	248

Shaft type	OMFB code
DIN 5480 W20x1,25x14x9g	008
DIN 5480 W25x1,25x18x9g	011
DIN 5480 W30x2x14x9g	014
DIN 5480 W32x2x14x9g	017
DIN 5480 W35x2x16x9g	020
DIN 5480 W40x2x18x9g	023
DIN 5480 W45x2x21x9g	026
DIN 6885 K20 - ø20 k6	041
DIN 6885 K25 - ø25 k6	044
DIN 6885 K30 - ø30 k6	047
DIN 6885 K35 - ø35 k6	050
DIN 6885 K40 - ø40 k6	053
DIN 6885 K45 - ø45 k6	056
GOST 6033 20xf7x1,5x9g	101
GOST 6033 25xf7x1,5x9g	104
GOST 6033 35xf7x2x9g	107
GOST 6033 40xf7x2x9g	110
GOST 6033 45xh8x2x9g	113

Rear cover and portings	OMFB code
BSPP (GAS) 40°	01
BSPP (GAS) 90° + LATERAL	02
BSPP (GAS) 40° + LATERAL	04
UN 40°	05
SAE 6000 - 40° METRIC SCREWS VERTICAL	10
SAE 6000 - 40° METRIC SCREWS HORIZONTAL	11
SAE 6000 - 90° METRIC SCREWS VERTICAL	12
SAE 6000 - 90° METRIC SCREWS HORIZONTAL	13
SAE 6000 - METRIC SCREWS LATERAL	14
SAE 6000 - METRIC SCREWS LATERAL + PANEL	15
SAE 6000 - 40° UNC SCREWS VERTICAL	20
SAE 6000 - 40° UNC SCREWS HORIZONTAL	21

012
017
025
034
040
047
055
064
080
091
108
130

HPM code	Description	
24001104012	Flange	ISO 3019-2 4H ø80 LONG
	Shaft	DIN 5480 W25x1,25x18x9g
	Portings	BSPP (GAS) 40° + LATERAL
	Displacement	012 cc

CODING EXAMPLE

pag.21

OVERALL MOTORS DIMENSIONS

OVERALL MOTOR DIMENSION WITH 40° REAR COVER

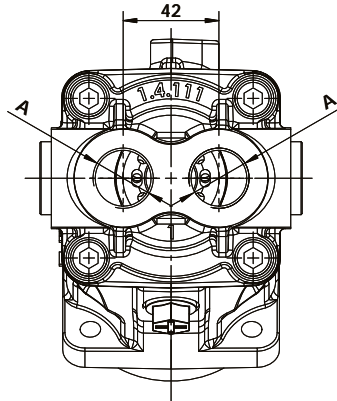
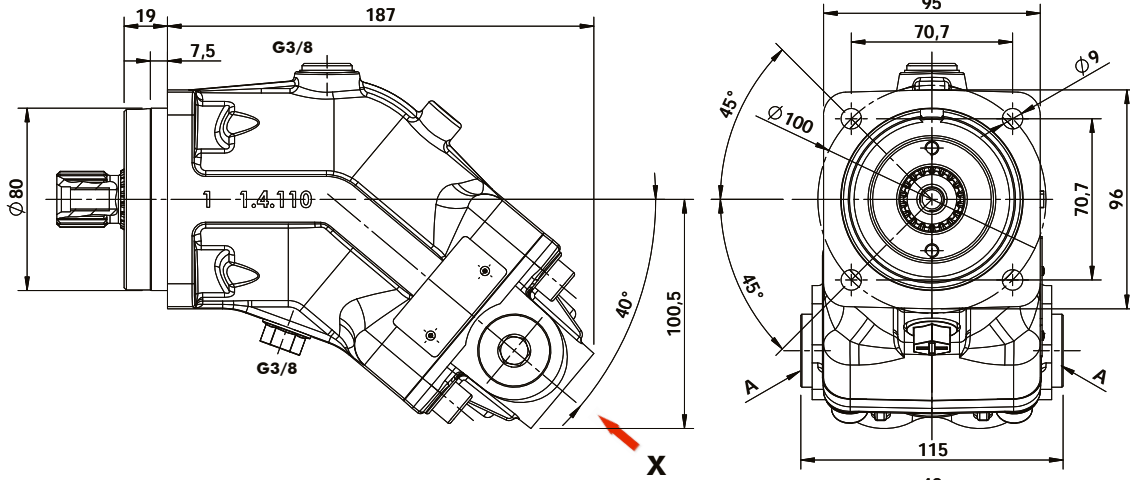

A	G 3/4	04 ●
----------	-------	------

OMFB P/N STRUCTURE

FLANGE	SHAFT	PORTS	DISPLACEMENT
240	xxx ■	04 ●	xxx

SHAFTS

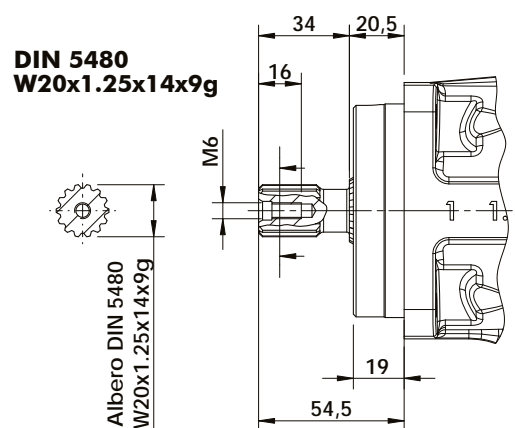
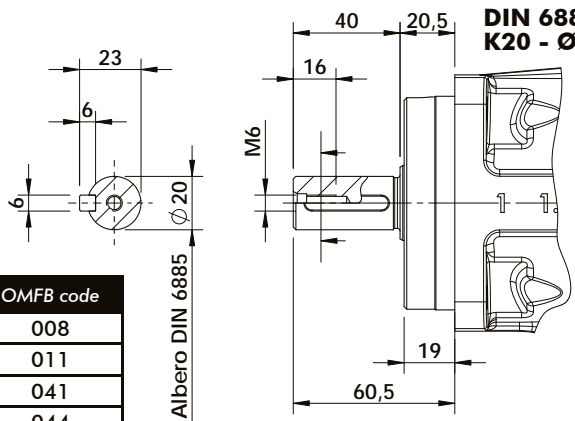
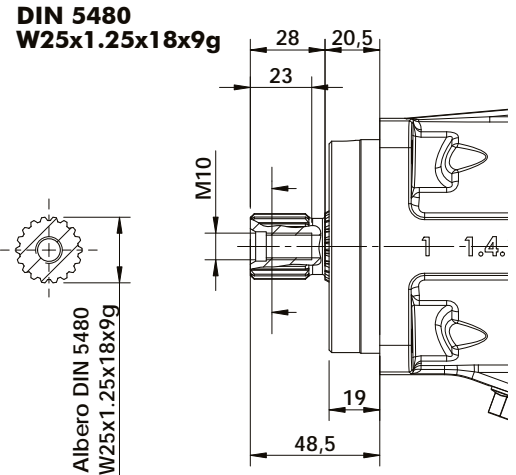
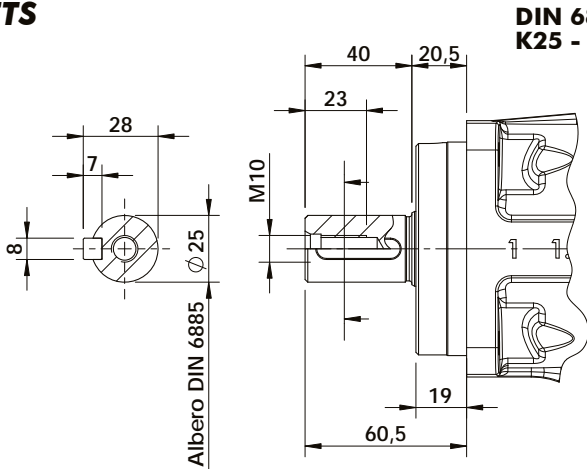

SHAFT	OMFB code
W20	008
W25	011
K20	041
K25	044

BENT AXIS PISTON MOTORS SERIES "HPM" FLANGE ISO 3019-2

FLANGE Ø 100

HPM

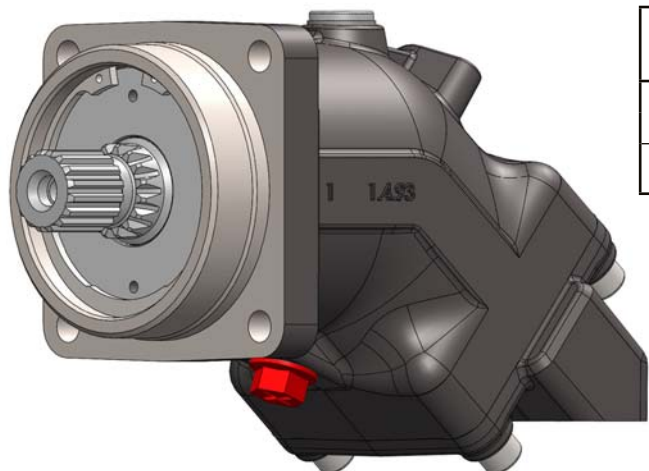

SAE FLANGE	ISO FLANGE mm	DISPLACEMENT cm ³	VALVES OFFSET mm	Z (THEET) n°	SENSOR DEPTH mm
SAE B	Ø80	12-17	42	27	18,4
	Ø100	25-34	59		
SAE C	Ø125	40-47 55-64	75	32	
	Ø140	80-91	84	38	
	Ø160	108-130	99		32

P	Motor with speed sensor option
M	Motor complete with selected speed sensor already mounted

(see page 51)

VERSIONS CODING

FLANGE TYPE

--	--	--

SHAFT

--	--	--

REAR COVER & PORTINGS

--	--

DISPLACEMENT

--	--	--

VARIANTS

--

Flange type	OMFB code
ISO 3019-2 4H ø 80 LONG	240
ISO 3019-2 4H ø100 LONG	242
ISO 3019-2 4H ø125 LONG	244
ISO 3019-2 4H ø140 LONG	246
ISO 3019-2 4H ø160 LONG	248

Shaft type	OMFB code
DIN 5480 W20x1,25x14x9g	008
DIN 5480 W25x1,25x18x9g	011
DIN 5480 W30x2x14x9g	014
DIN 5480 W32x2x14x9g	017
DIN 5480 W35x2x16x9g	020
DIN 5480 W40x2x18x9g	023
DIN 5480 W45x2x21x9g	026

DIN 6885 K20 - ø20 k6	041
DIN 6885 K25 - ø25 k6	044
DIN 6885 K30 - ø30 k6	047
DIN 6885 K35 - ø35 k6	050
DIN 6885 K40 - ø40 k6	053
DIN 6885 K45 - ø45 k6	056

GOST 6033 20xf7x1,5x9g	101
GOST 6033 25xf7x1,5x9g	104
GOST 6033 35xf7x2x9g	107
GOST 6033 40xf7x2x9g	110
GOST 6033 45xh8x2x9g	113

Rear cover and portings	OMFB code
BSPP (GAS) 40°	01
BSPP (GAS) 90° + LATERAL	02
BSPP (GAS) LATERAL	03
UN 40°	05
SAE 6000 - 40° METRIC SCREWS VERTICAL	10
SAE 6000 - 40° METRIC SCREWS HORIZONTAL	11
SAE 6000 - 90° METRIC SCREWS VERTICAL	12
SAE 6000 - 90° METRIC SCREWS HORIZONTAL	13
SAE 6000 - METRIC SCREWS LATERAL	14
SAE 6000 - METRIC SCREWS LATERAL + PANEL	15
SAE 6000 - 40° UNC SCREWS VERTICAL	20
SAE 6000 - 40° UNC SCREWS HORIZONTAL	21

012
017
025
034
040
047
055
064
080
091
108
130

HPM code	Description	
24201101025	Flange	ISO 3019-2 4H ø100 LONG
	Shaft	DIN 5480 W25x1,25x18x9g
	Portings	BSPP (GAS) 40°
	Displacement	025 cc

CODING EXAMPLE

pag.23

OVERALL MOTORS DIMENSIONS

OVERALL MOTOR DIMENSION WITH 40° REAR COVER

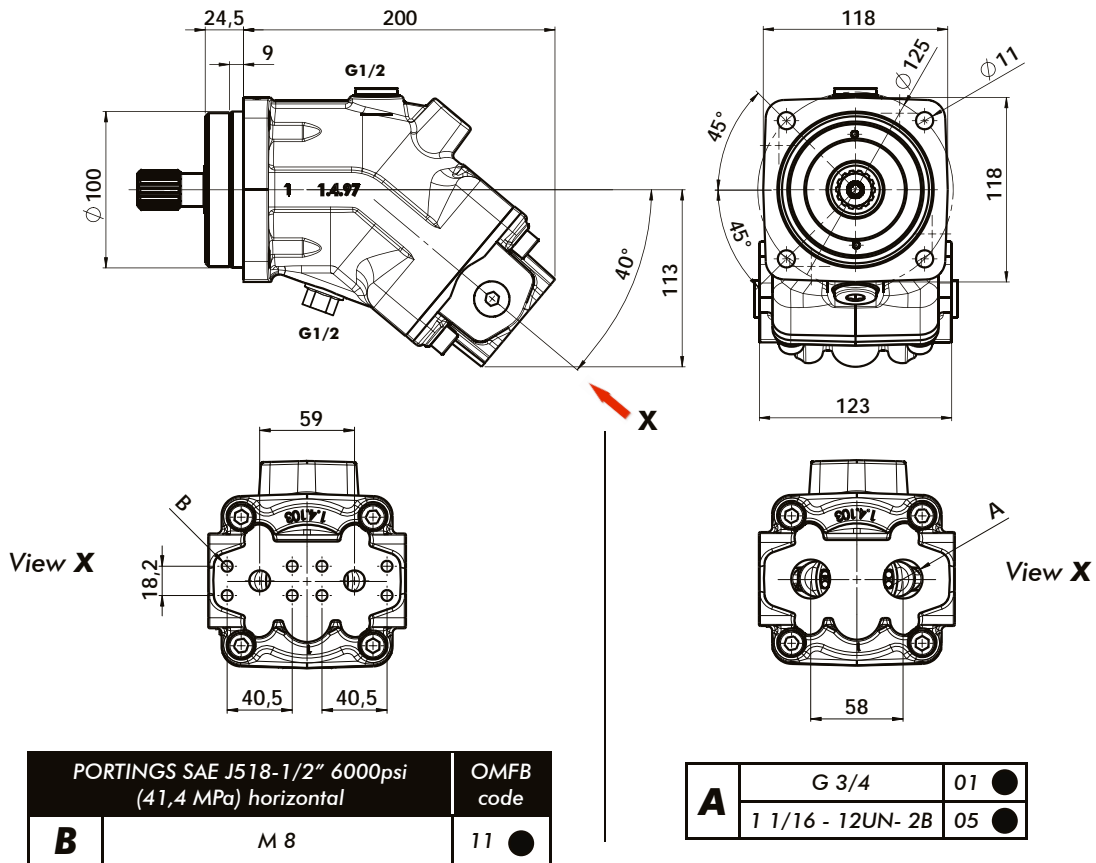

OVERALL MOTOR DIMENSION WITH 90° REAR COVER

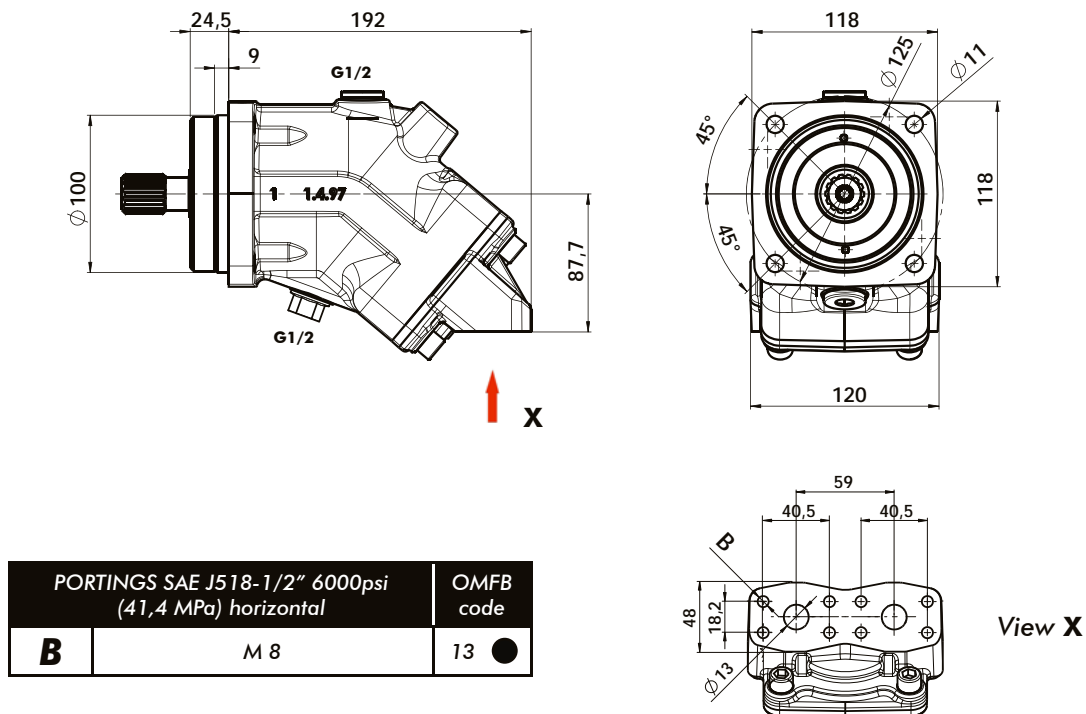

OMFB P/N STRUCTURE

FLANGE	SHAFT	PORTS	DISPLACEMENT
242	xxx ■	xx ●	xxx

pag.24

O.M.F.B. S.p.A. Hydraulic Components

We reserve the right to make any changes without notice.

Edition 2016.04 No reproduction, however partial, is permitted.

Via Cave, 7/9 25050 Provaglio d'Iseo (Brescia) Italy Tel.: +39.030.9830611

Fax: +39.030.9839207-208 Internet:www.omfb.it e-mail:info@omfb.it

OVERALL MOTORS DIMENSIONS

OVERALL MOTOR DIMENSION WITH REAR LATERAL COVER

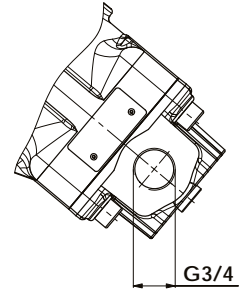
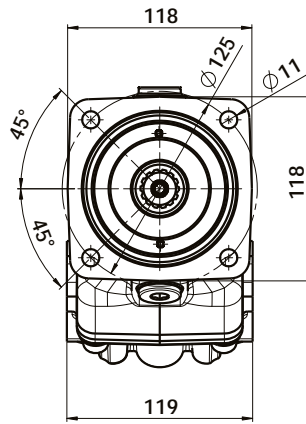
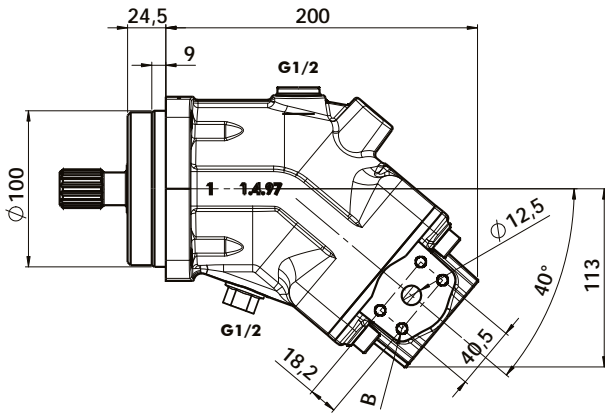

PORTINGS SAE J518-1/2" 6000psi (41,4 MPa) lateral		OMFB code
B	M 8	14 ●

PORTINGS ONLY LATERAL	OMFB code
G 3/4	03 ●

SHAFTS

**DIN 6885
K30 - Ø30 k6**

**DIN 5480
W30x2x14x9g**

SHAFT	OMFB code
K25	044
K30	047
W25	011
W30	014

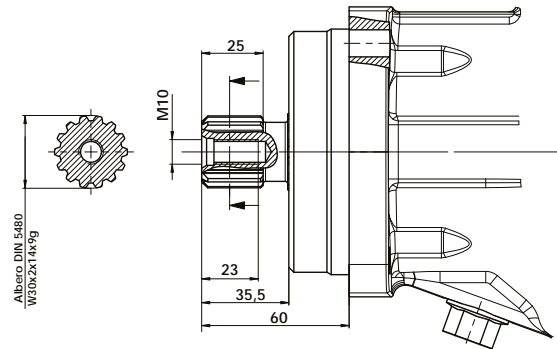
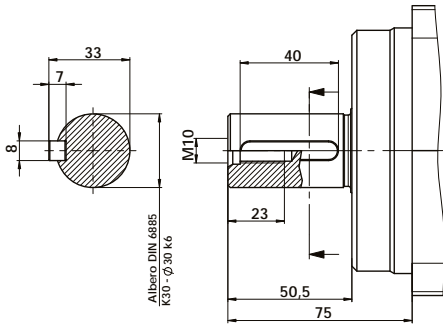

Data: Venerdì 28 settembre 2018

**DIN 6885
K25 - Ø25 k6**

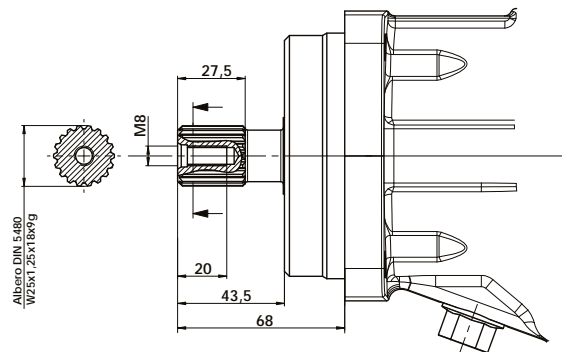
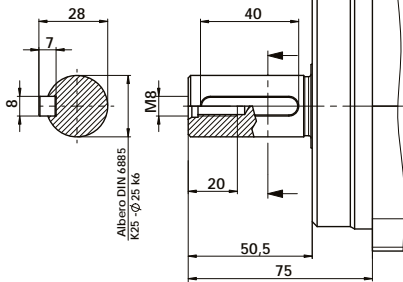

Displacement	cm ³ /rev	34
Working pressure	Max. intermittent	370 bar
	Max. continuous	320 bar



**DIN 5480
W25x1.25x18x9g**

Codice foglio: 997-244-00011 Rev: AL

BENT AXIS PISTON MOTORS SERIES "HPM" FLANGE ISO 3019-2

FLANGE Ø 125

HPM

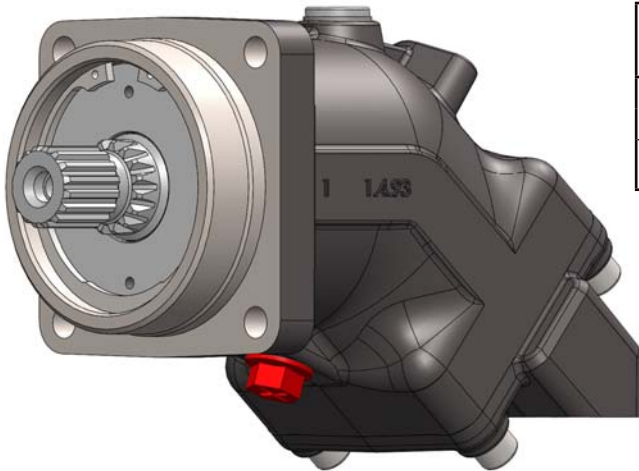

SAE FLANGE	ISO FLANGE mm	DISPLACEMENT cm ³	VALVES OFFSET mm	Z (THEET) n°	SENSOR DEPTH mm
SAE B	Ø80	12-17	42	27	18,4
	Ø100	25-34	59		
SAE C	Ø125	40-47 55-64	75	32	
	Ø140	80-91	84	38	
	Ø160	108-130	99		32

Codice fascicolo:997-400-24411

P	Motor with speed sensor option
M	Motor complete with selected speed sensor already mounted

(see page 51)

VERSIONS CODING

FLANGE TYPE

--	--	--

SHAFT

--	--	--

REAR COVER & PORTINGS

--	--

DISPLACEMENT

--	--	--

VARIANTS

--

Flange type	OMFB code	Shaft type	OMFB code	Rear cover and portings	OMFB code	
ISO 3019-2 4H ø 80 LONG	240	DIN 5480 W20x1,25x14x9g	008	BSPP (GAS) 40°	01	012
ISO 3019-2 4H ø100 LONG	242	DIN 5480 W25x1,25x18x9g	011	BSPP (GAS) 90° + LATERAL	02	017
ISO 3019-2 4H ø125 LONG	244	DIN 5480 W30x2x14x9g	014	UN 40°	05	025
ISO 3019-2 4H ø140 LONG	246	DIN 5480 W32x2x14x9g	017	SAE 6000 - 40° METRIC SCREWS VERTICAL	10	034
ISO 3019-2 4H ø160 LONG	248	DIN 5480 W35x2x16x9g	020	SAE 6000 - 40° METRIC SCREWS HORIZONTAL	11	040
		DIN 5480 W40x2x18x9g	023	SAE 6000 - 90° METRIC SCREWS VERTICAL	12	047
		DIN 5480 W45x2x21x9g	026	SAE 6000 - 90° METRIC SCREWS HORIZONTAL	13	055
		DIN 6885 K20 - ø20 k6	041	SAE 6000 - METRIC SCREWS LATERAL	14	064
		DIN 6885 K25 - ø25 k6	044	SAE 6000 - METRIC SCREWS LATERAL + PANEL	15	080
		DIN 6885 K30 - ø30 k6	047	SAE 6000 - 40° UNC SCREWS VERTICAL	20	091
		DIN 6885 K35 - ø35 k6	050	SAE 6000 - 40° UNC SCREWS HORIZONTAL	21	108
		DIN 6885 K40 - ø40 k6	053			130
		DIN 6885 K45 - ø45 k6	056			
		GOST 6033 20xf7x1,5x9g	101			
		GOST 6033 25xf7x1,5x9g	104			
		GOST 6033 35xf7x2x9g	107			
		GOST 6033 40xf7x2x9g	110			
		GOST 6033 45xh8x2x9g	113			

Data: Venerdì 28 settembre 2018

Rev: AL

Codice foglio:997-244-00011

HPM code	Description	
24402001064	Flange	ISO 3019-2 4H ø125 LONG
	Shaft	DIN 5480 W35x2x16x9g
	Portings	BSPP (GAS) 40°
	Displacement	064 cc

CODING EXAMPLE

pag.27



O.M.F.B. S.p.A. Hydraulic Components

We reserve the right to make any changes without notice.

Edition 2016.04 No reproduction, however partial, is permitted.

Via Cave, 7/9 25050 Provaglio d'Iseo (Brescia) Italy Tel.: +39.030.9830611

Fax: +39.030.9839207-208 Internet:www.omfb.it e-mail:info@omfb.it

OVERALL MOTORS DIMENSIONS

OVERALL MOTOR DIMENSION WITH 40° REAR COVER

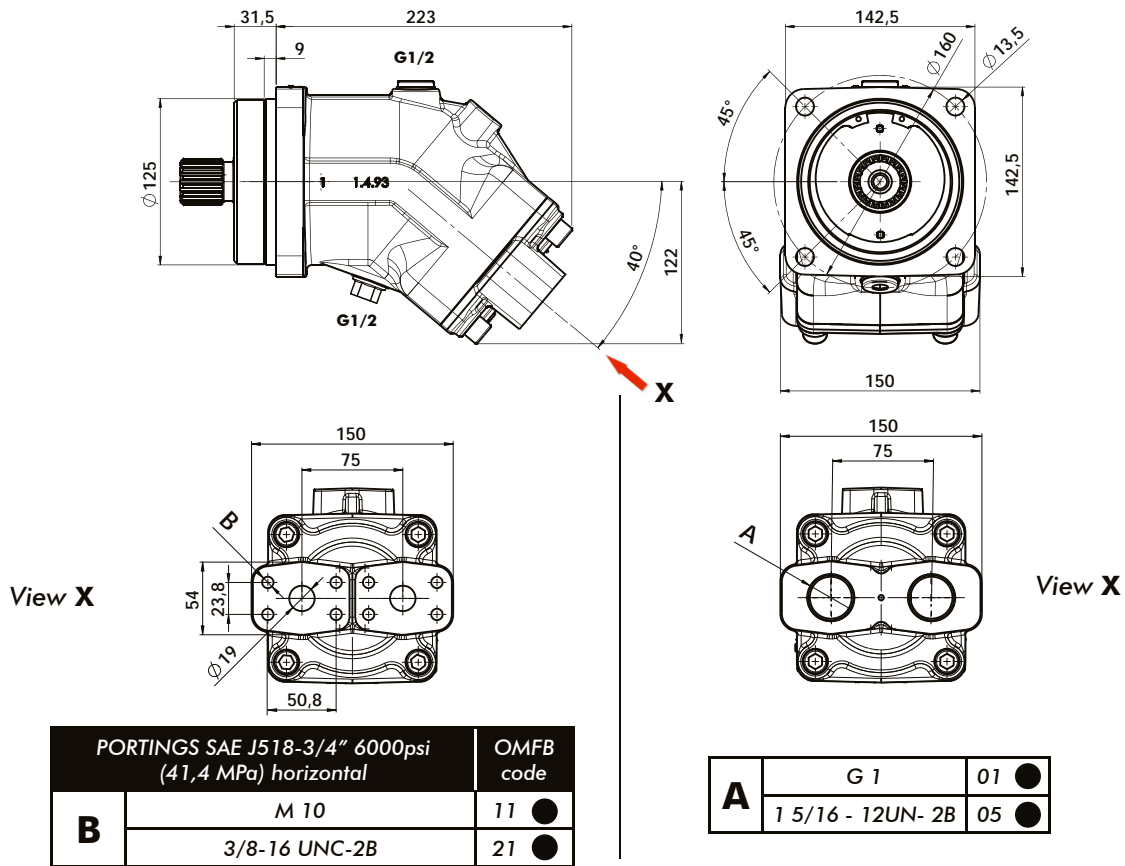

OVERALL MOTOR DIMENSION WITH 90° REAR COVER

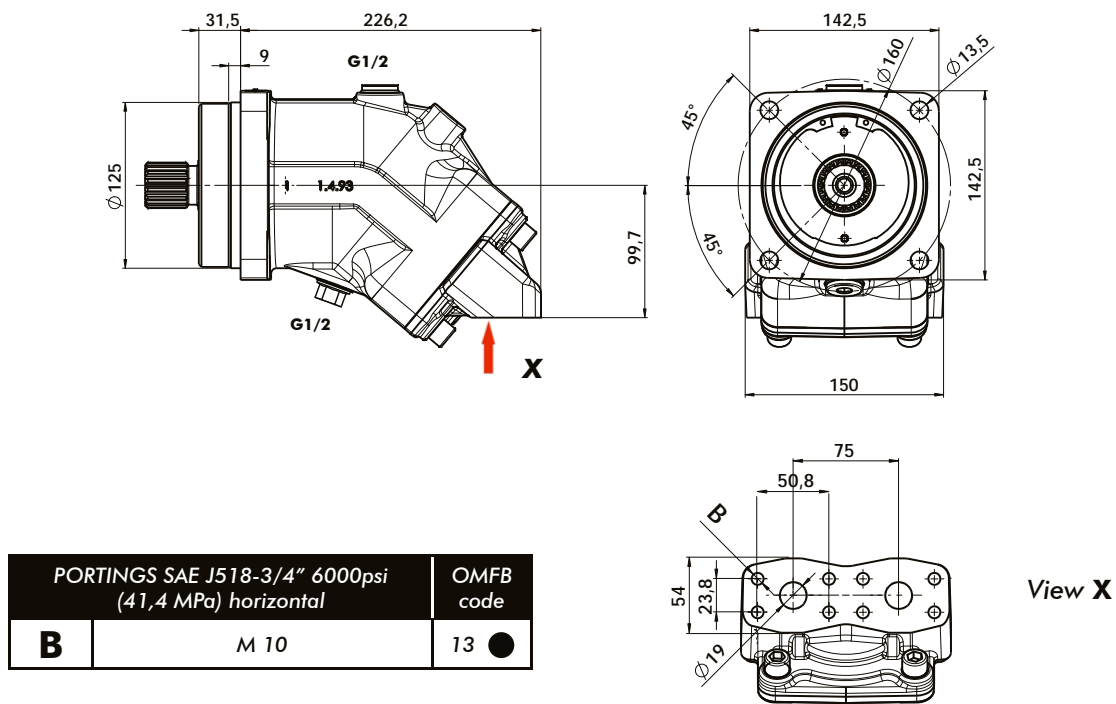

OMFB P/N STRUCTURE

FLANGE	SHAFT	PORTS	DISPLACEMENT
242	xxx ■	xx ●	xxx

OVERALL MOTORS DIMENSIONS

OVERALL MOTOR DIMENSION WITH REAR LATERAL COVER+PANEL

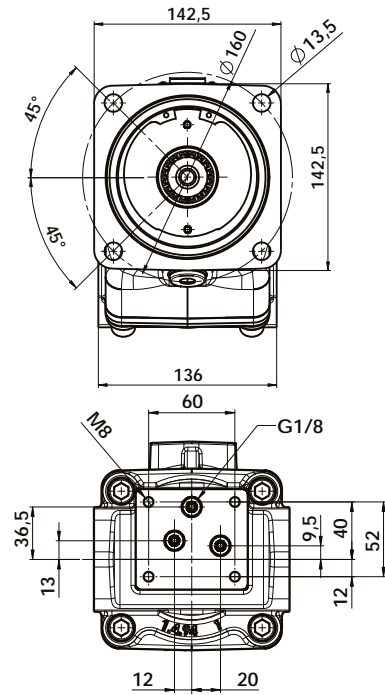
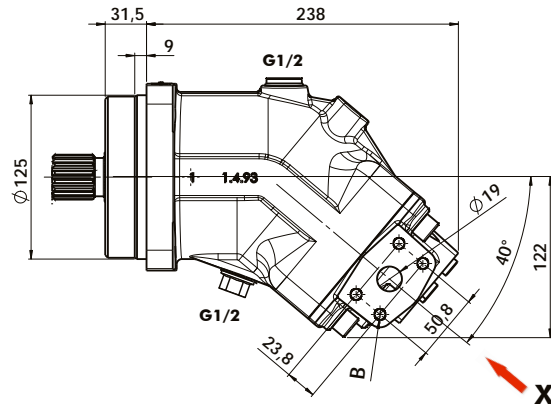

PORTINGS SAE J518-3/4" 6000psi (41,4 MPa) lateral+panel		OMFB code
B	M 10	15 ●

OVERALL MOTOR DIMENSION WITH REAR LATERAL COVER

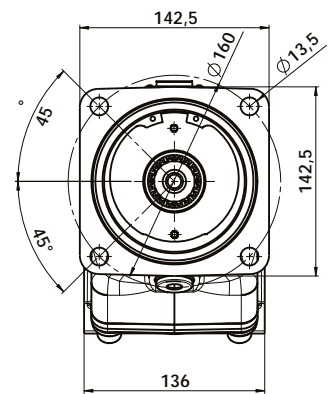
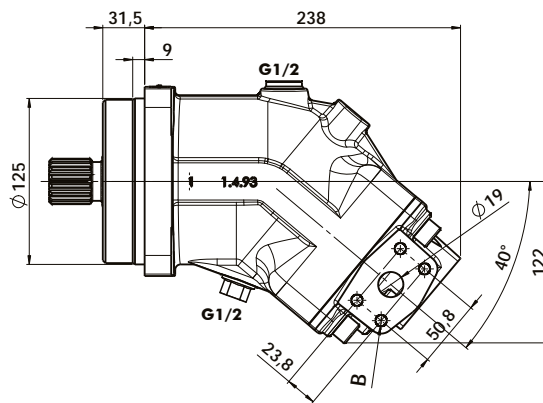

PORTINGS SAE J518-3/4" 6000psi (41,4 MPa) lateral		OMFB code
B	M 10	14 ●

SHAFTS

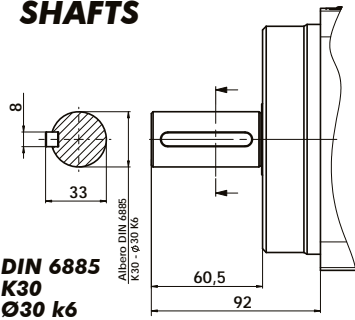

Displacement	cm ³ /rev	55	64
		Working pressure	Max. intermittent
Working pressure	Max. continuous	320	270

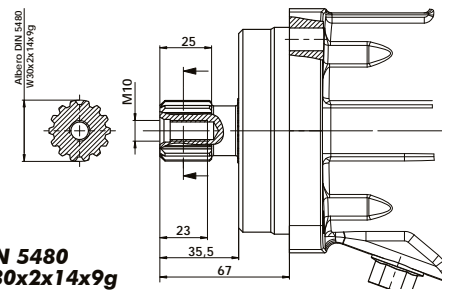

**DIN 6885
K30
Ø30 k6**

**DIN 5480
W30x2x14x9g**

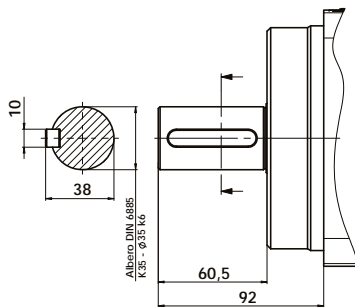

SHAFT	OMFB code
■ K30	047
■ K35	050
■ W30	014
■ W35	020

**DIN 6885
K35
Ø35 k6**

**DIN 5480
W35x2x16x9g**

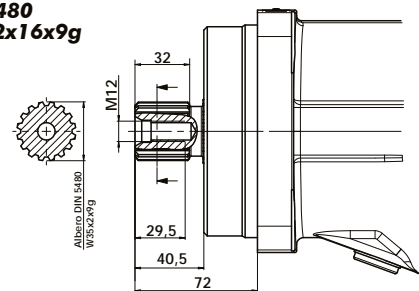

BENT AXIS PISTON MOTORS SERIES "HPM" FLANGE ISO 3019-2

FLANGE Ø 140

HPM

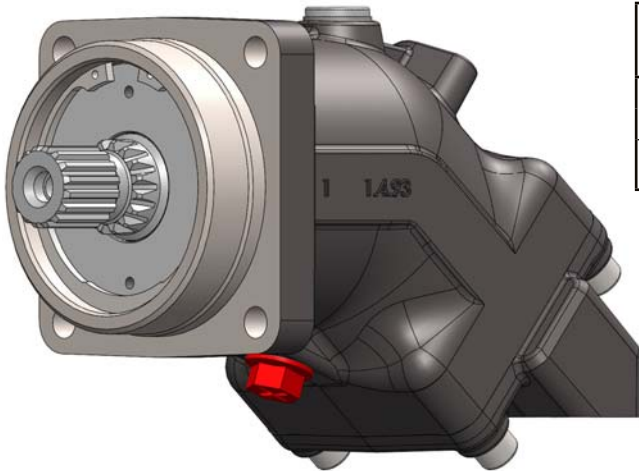

SAE FLANGE	ISO FLANGE mm	DISPLACEMENT cm ³	VALVES OFFSET mm	Z (THEET) n°	SENSOR DEPTH mm
SAE B	Ø80	12-17	42	27	18,4
	Ø100	25-34	59		
SAE C	Ø125	40-47 55-64	75	32	
	Ø140	80-91	84	38	
	Ø160	108-130	99		

Codice fascicolo:997-400-24411

P	Motor with speed sensor option
M	Motor complete with selected speed sensor already mounted

(see page 51)

VERSIONS CODING

FLANGE TYPE		SHAFT		REAR COVER & PORTINGS		DISPLACEMENT		VARIANTS	
ISO 3019-2 4H ø 80 LONG	240	DIN 5480 W20x1,25x14x9g	008	BSPP (GAS) 40°	01				012
ISO 3019-2 4H ø100 LONG	242	DIN 5480 W25x1,25x18x9g	011	BSPP (GAS) 90° + LATERAL	02				017
ISO 3019-2 4H ø125 LONG	244	DIN 5480 W30x2x14x9g	014	UN 40°	05				025
ISO 3019-2 4H ø140 LONG	246	DIN 5480 W32x2x14x9g	017	SAE 6000 - 40° METRIC SCREWS VERTICAL	10				034
ISO 3019-2 4H ø160 LONG	248	DIN 5480 W35x2x16x9g	020	SAE 6000 - 40° METRIC SCREWS HORIZONTAL	11				040
		DIN 5480 W40x2x18x9g	023	SAE 6000 - 90° METRIC SCREWS VERTICAL	12				047
		DIN 5480 W45x2x21x9g	026	SAE 6000 - 90° METRIC SCREWS HORIZONTAL	13				055
		DIN 6885 K20 - ø20 k6	041	SAE 6000 - METRIC SCREWS LATERAL	14				064
		DIN 6885 K25 - ø25 k6	044	SAE 6000 - METRIC SCREWS LATERAL + PANEL	15				080
		DIN 6885 K30 - ø30 k6	047	SAE 6000 - 40° UNC SCREWS VERTICAL	20				091
		DIN 6885 K35 - ø35 k6	050	SAE 6000 - 40° UNC SCREWS HORIZONTAL	21				108
		DIN 6885 K40 - ø40 k6	053						130
		DIN 6885 K45 - ø45 k6	056						
		GOST 6033 20xf7x1,5x9g	101						
		GOST 6033 25xf7x1,5x9g	104						
		GOST 6033 35xf7x2x9g	107						
		GOST 6033 40xf7x2x9g	110						
		GOST 6033 45xh8x2x9g	113						

only for 80cc

HPM code	Description	
24602314080	Flange	ISO 3019-2 4H ø140 LONG
	Shaft	DIN 5480 W40x2x18x9g
	Portings	SAE 6000 - METRIC SCREWS LATERAL
	Displacement	080 cc

CODING EXAMPLE

pag.31



O.M.F.B. S.p.A. Hydraulic Components

We reserve the right to make any changes without notice.

Edition 2016.04 No reproduction, however partial, is permitted.

Via Cave, 7/9 25050 Provaglio d'Iseo (Brescia) Italy Tel.: +39.030.9830611

Fax: +39.030.9839207-208 Internet:www.omfb.it e-mail:info@omfb.it

Data: Venerdì 28 settembre 2018

Rev: AL

Codice foglio:997-244-00011

OVERALL MOTORS DIMENSIONS

OVERALL MOTOR DIMENSION WITH 40° REAR COVER

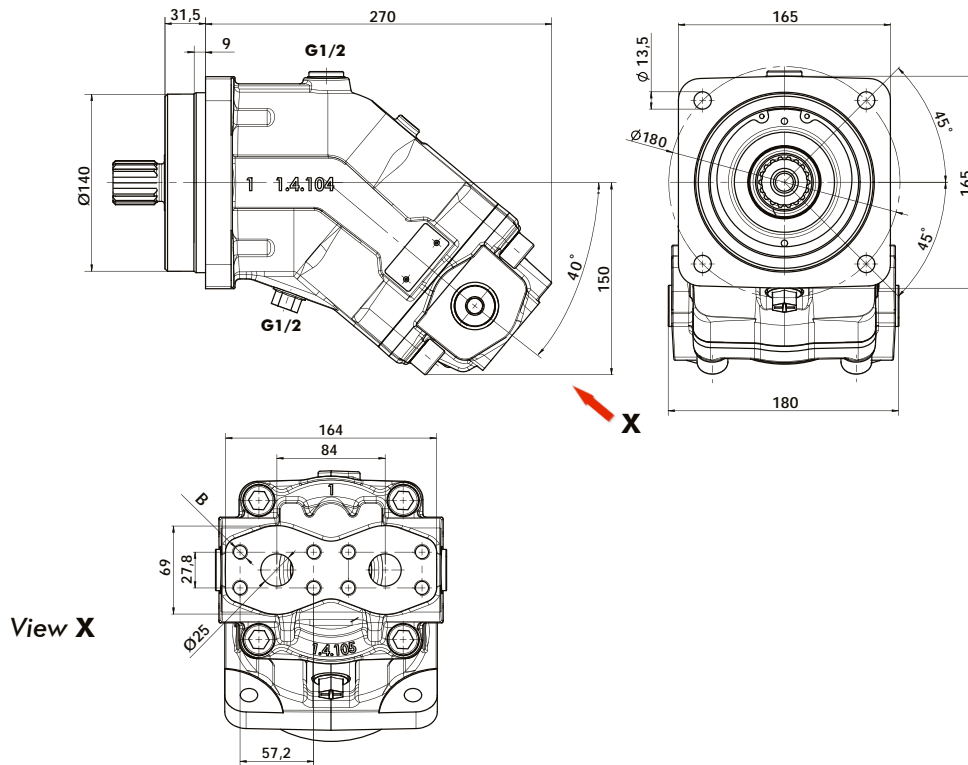

PORTINGS SAE J518-1" 6000psi (41,4 MPa) orizzontale		OMFB code
B	M 12	11 ●

OVERALL MOTOR DIMENSION WITH 90° REAR COVER

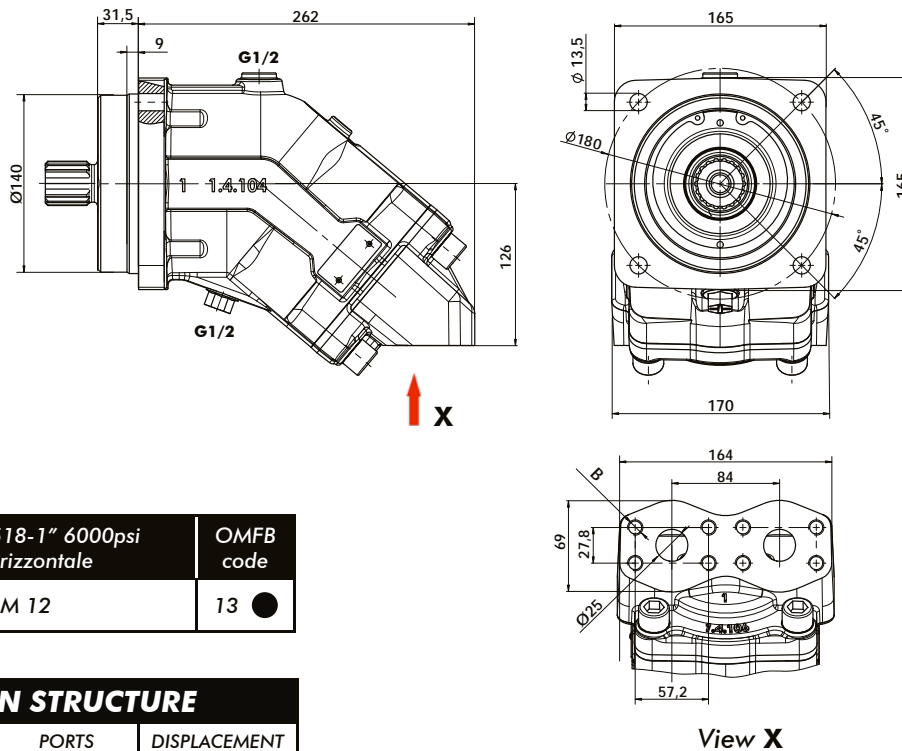

PORTINGS SAE J518-1" 6000psi (41,4 MPa) orizzontale		OMFB code
B	M 12	13 ●

OMFB P/N STRUCTURE			
FLANGE	SHAFT	PORTS	DISPLACEMENT
246	xxx ■	xx ●	xxx

OVERALL MOTOR DIMENSIONS

OVERALL MOTOR DIMENSION WITH REAR LATERAL COVER + PANEL

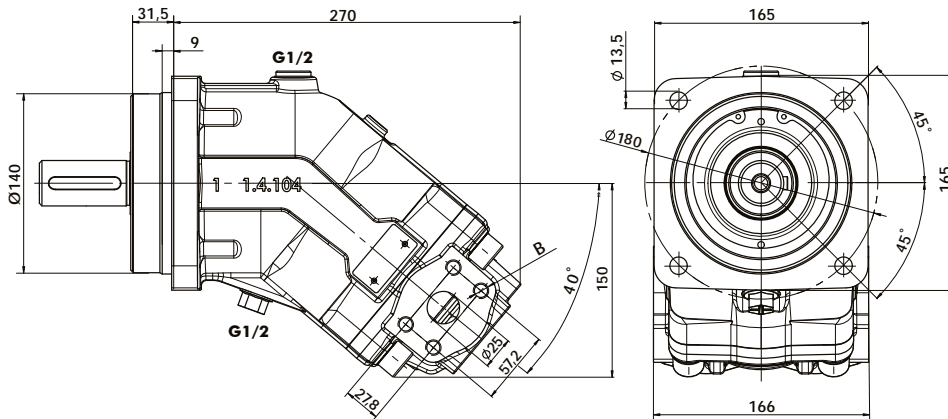

PORTINGS SAE J518-1" 6000psi (41,4 MPa) laterale		OMFB code
B	M 12	14 ●

SHAFTS

SHAFT	OMFB code
K35	050
K40	053
W35	020
W40	023

**DIN 6885
K35 - Ø35 k6**

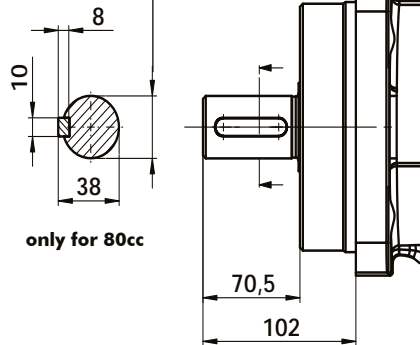

**DIN 5480
W35x2x16x9g**

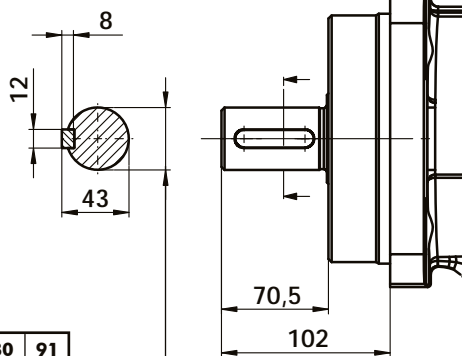
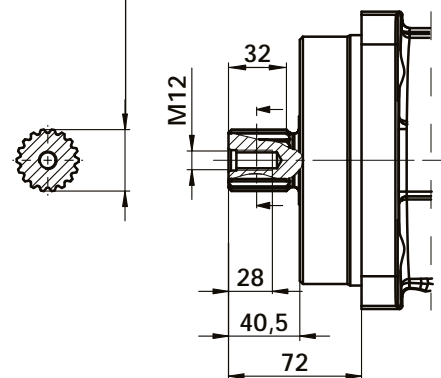

**DIN 6885
K40 - Ø40 k6**

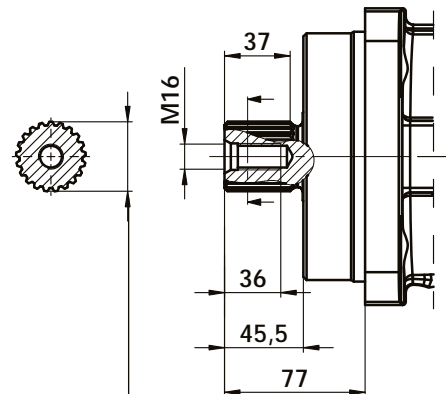

**DIN 5480
W40x2x18x9g**

Displacement	cm ³ /rev	80	91
		Max. intermittent	380
Working pressure bar	Max. continuous	330	290

BENT AXIS PISTON MOTORS SERIES "HPM" FLANGE ISO 3019-2

FLANGE Ø 160

HPM

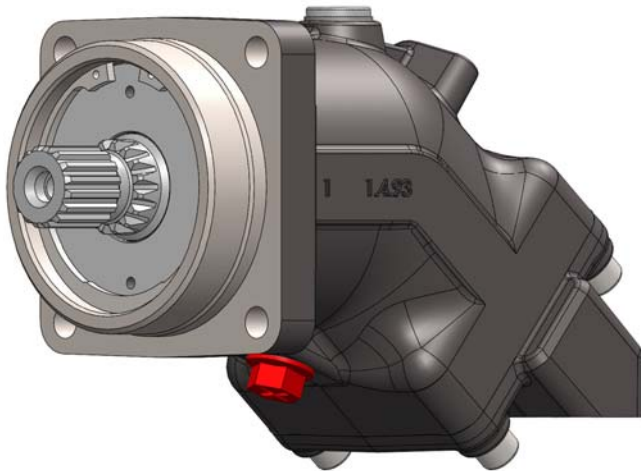

SAE FLANGE	ISO FLANGE mm	DISPLACEMENT cm ³	VALVES OFFSET mm	Z (THEET) n°	SENSOR DEPTH mm
SAE B	Ø80	12-17	42	27	18,4
	Ø100	25-34	59		
SAE C	Ø125	40-47 55-64	75	32	
	Ø140	80-91	84	38	
	Ø160	108-130	99		32

VERSIONS CODING

P	Motor with speed sensor option
M	Motor complete with selected speed sensor already mounted

(see page 51)

FLANGE
TYPE

SHAFT

REAR COVER
& PORTINGS

DISPLACEMENT

VARIANTS

Flange type	OMFB code	Shaft type	OMFB code	Rear cover and portings	OMFB code	
ISO 3019-2 4H ø 80 LONG	240	DIN 5480 W20x1,25x14x9g	008	BSPP (GAS) 40°	01	012
ISO 3019-2 4H ø100 LONG	242	DIN 5480 W25x1,25x18x9g	011	BSPP (GAS) 90° + LATERAL	02	017
ISO 3019-2 4H ø125 LONG	244	DIN 5480 W30x2x14x9g	014	UN 40°	05	025
ISO 3019-2 4H ø140 LONG	246	DIN 5480 W32x2x14x9g	017	SAE 6000 - 40° METRIC SCREWS VERTICAL	10	034
ISO 3019-2 4H ø160 LONG	248	DIN 5480 W35x2x16x9g	020	SAE 6000 - 40° METRIC SCREWS HORIZONTAL	11	040
		DIN 5480 W40x2x18x9g	023	SAE 6000 - 90° METRIC SCREWS VERTICAL	12	047
		DIN 5480 W45x2x21x9g	026	SAE 6000 - 90° METRIC SCREWS HORIZONTAL	13	055
		DIN 6885 K20 - ø20 k6	041	SAE 6000 - METRIC SCREWS LATERAL	14	064
		DIN 6885 K25 - ø25 k6	044	SAE 6000 - METRIC SCREWS LATERAL + PANEL	15	080
		DIN 6885 K30 - ø30 k6	047	SAE 6000 - 40° UNC SCREWS VERTICAL	20	090
		DIN 6885 K35 - ø35 k6	050	SAE 6000 - 40° UNC SCREWS HORIZONTAL	21	108
		DIN 6885 K40 - ø40 k6	053			130
		DIN 6885 K45 - ø45 k6	056			
		GOST 6033 20xf7x1,5x9g	101			
		GOST 6033 25xf7x1,5x9g	104			
		GOST 6033 35xf7x2x9g	107			
		GOST 6033 40xf7x2x9g	110			
		GOST 6033 45xh8x2x9g	113			

HPM code	Description	
24802314108	Flange	ISO 3019-2 4H ø160 LONG
	Shaft	DIN 5480 W40x2x18x9g
	Portings	SAE 6000 - METRIC SCREWS LATERAL
	Displacement	108 cc

CODING EXAMPLE

pag.35

OVERALL MOTORS DIMENSIONS

OVERALL MOTOR DIMENSION WITH 40° REAR COVER

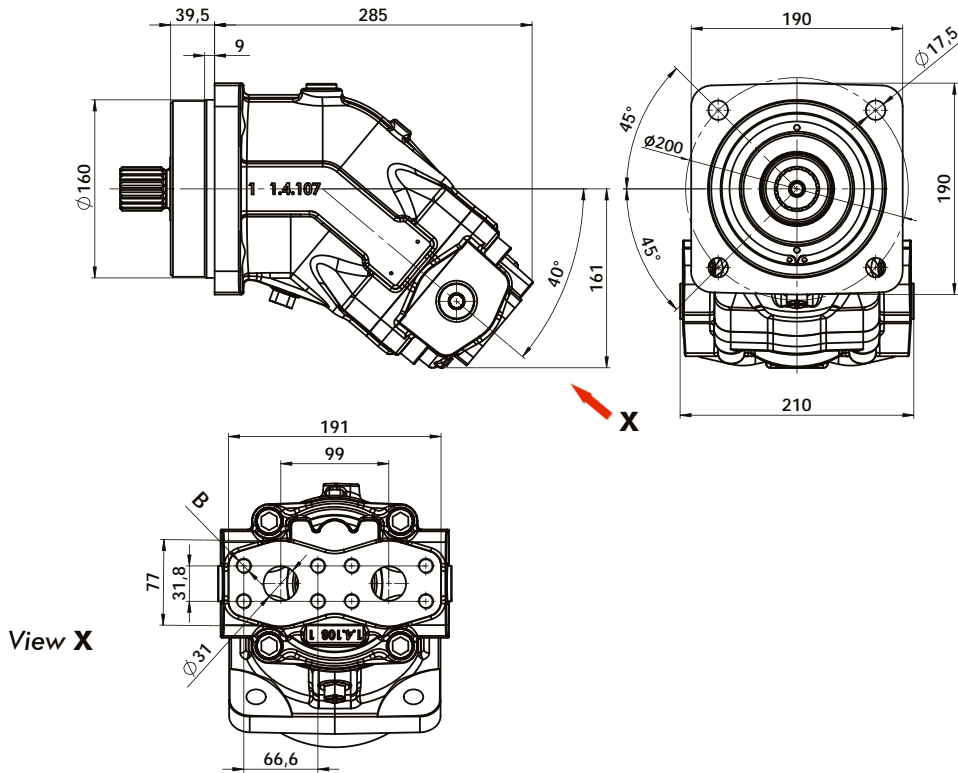

PORTINGS SAE J518-1 1/4" 6000psi (41,4 MPa) orizzontale		OMFB code
B	M 14	11 ●

OVERALL MOTOR DIMENSION WITH 90° REAR COVER

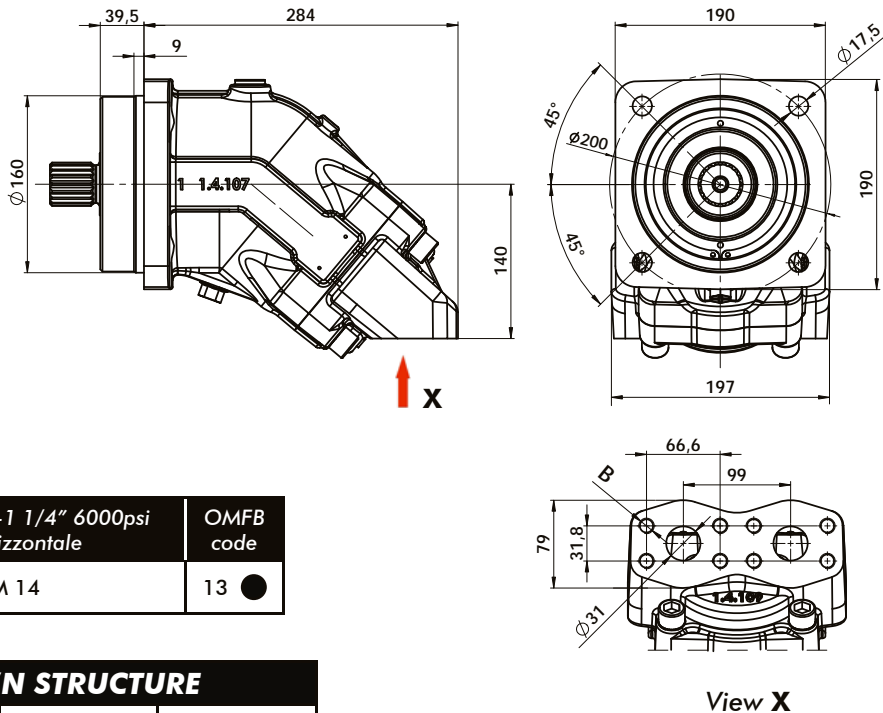

PORTINGS SAE J518-1 1/4" 6000psi (41,4 MPa) orizzontale		OMFB code
B	M 14	13 ●

OMFB P/N STRUCTURE			
FLANGE	SHAFT	PORTS	DISPLACEMENT
248	xxx ■	xx ●	xxx

OVERALL MOTORS DIMENSIONS

OVERALL MOTOR DIMENSION WITH REAR LATERAL COVER

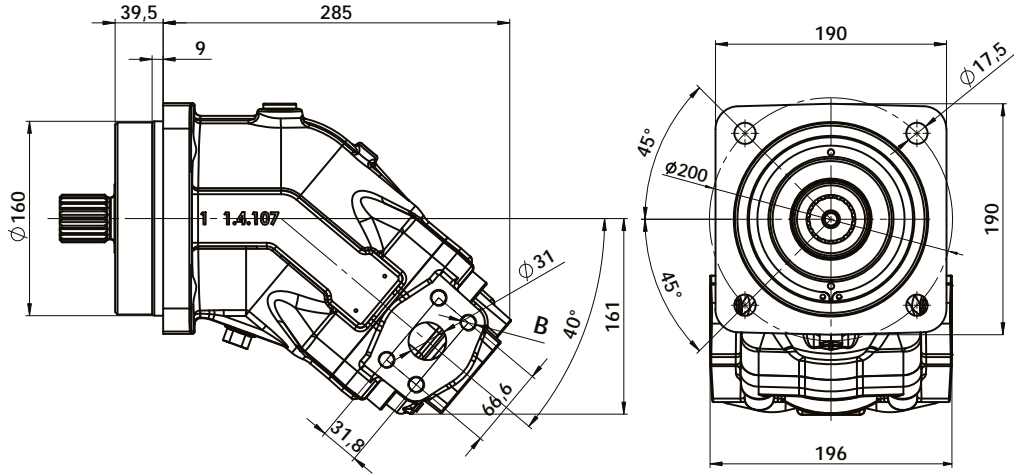

PORTINGS SAE J518-1 1/4" 6000psi (41,4 MPa) laterale		OMFB code
B	M 14	14 ●

SHAFTS

Displacement	cm ³ /rev	108
Working pressure	bar	
	Max. intermittent	310
	Max. continuous	260



SHAFT	OMFB code
K40	053
K45	056
W40	023
W45	026

**DIN 6885
K40 - Ø40 k6**

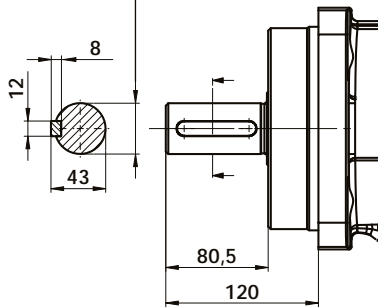

**DIN 5480
W40x2x18x9g**

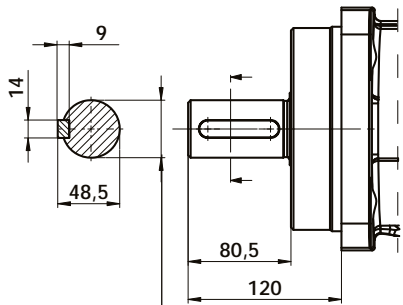
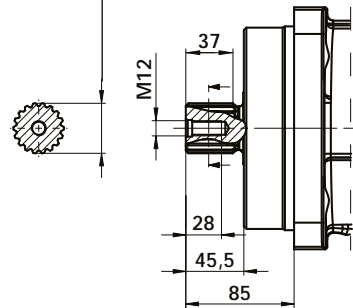

**DIN 6885
K45 - Ø45 k6**

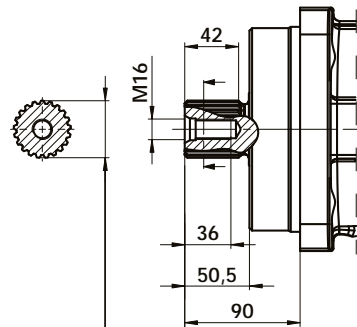

**DIN 5480
W45x2x21x9g**

Displacement	cm ³ /rev	108	130
Working pressure	bar		
	Max. intermittent	390	320
	Max. continuous	130	270



BENT AXIS PISTON MOTORS SERIES "HPM" FLANGE ISO 3019-1 SAE B 2 HOLES

Ø 101,6

HPM2



SAE FLANGE	ISO FLANGE mm	DISPLACEMENT cm ³	VALVES OFFSET mm	Z (THEET) n°	SENSOR DEPTH mm
SAE B	Ø80	12-17	42	27	18,4
	Ø100	25-34	59		
SAE C	Ø125	40-47 55-64	75	32	
	Ø140	80-91	84	38	
	Ø160	108-130	99		32

VERSIONS CODING

P	Motor with speed sensor option
M	Motor complete with selected speed sensor already mounted (see page 51)

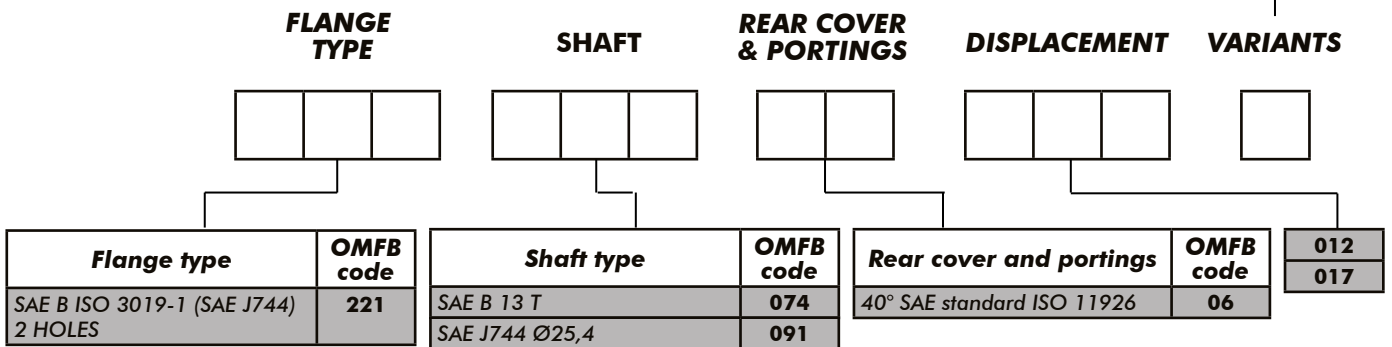

HPM code	Description	
22107406012	Flange	SAE B ISO 3019-1 (SAE J744) 2 HOLES
	Shaft	SAE B 13 T
	Portings	40° SAE standard ISO 11926
	Displacement	012 cc

**CODING
EXAMPLE**

OVERALL MOTORS DIMENSIONS

OVERALL MOTOR DIMENSION WITH 40° REAR COVER

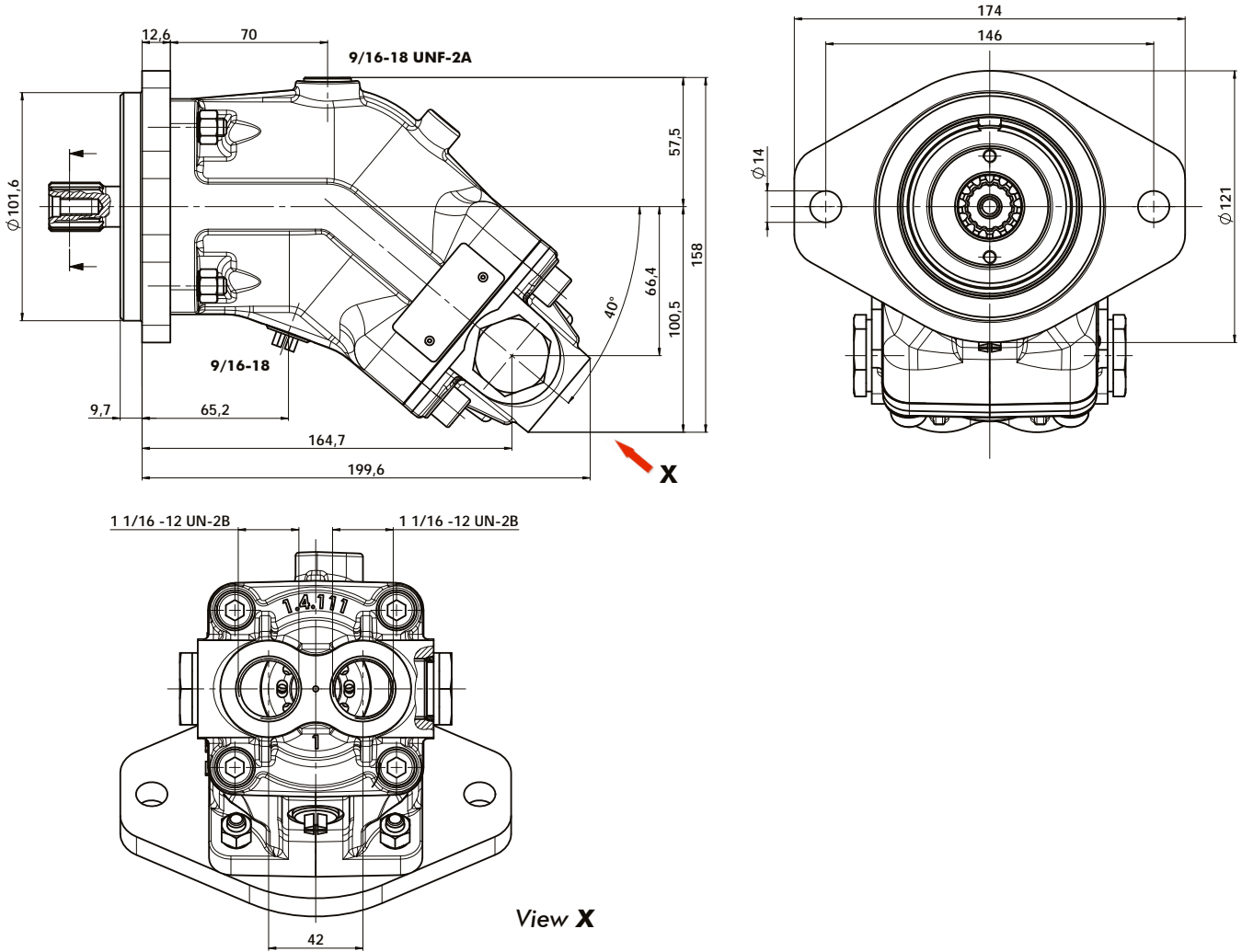

SHAFTS

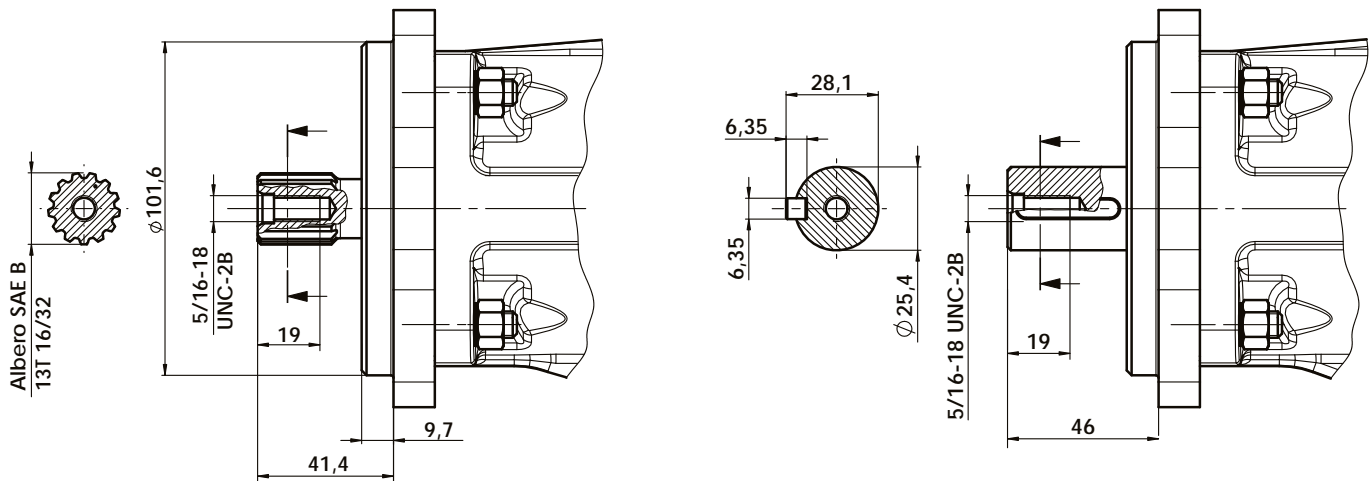

SAE B
13T 16/32DP 7/8"

pag.40

O.M.F.B. S.p.A. Hydraulic Components

We reserve the right to make any changes without notice.

Edition 2016.04 No reproduction, however partial, is permitted.

Via Cave, 7/9 25050 Provaglio d'Iseo (Brescia) Italy Tel.: +39.030.9830611
Fax: +39.030.9839207-208 Internet:www.omfb.it e-mail:info@omfb.it



Codice fascicolo:997-400-24411

Data: Venerdì 28 settembre 2018

Rev: AL

Codice foglio:997-244-00011

BENT AXIS PISTON MOTORS SERIES "HPM" FLANGE ISO 3019-1 SAE B 2 HOLES

Ø 101,6

HPM2



SAE FLANGE	ISO FLANGE mm	DISPLACEMENT cm ³	VALVES OFFSET mm	Z (THEET) n°	SENSOR DEPTH mm
SAE B	Ø80	12-17	42	27	18,4
	Ø100	25-34	59		
SAE C	Ø125	40-47 55-64	75	32	
	Ø140	80-91	84	38	
	Ø160	108-130	99		32

Codice fascicolo:997-400-24411

Data: Venerdì 28 settembre 2018

Rev: AL

Codice foglio:997-244-00011

P	Motor with speed sensor option
M	Motor complete with selected speed sensor already mounted (see page 51)

VERSIONS CODING

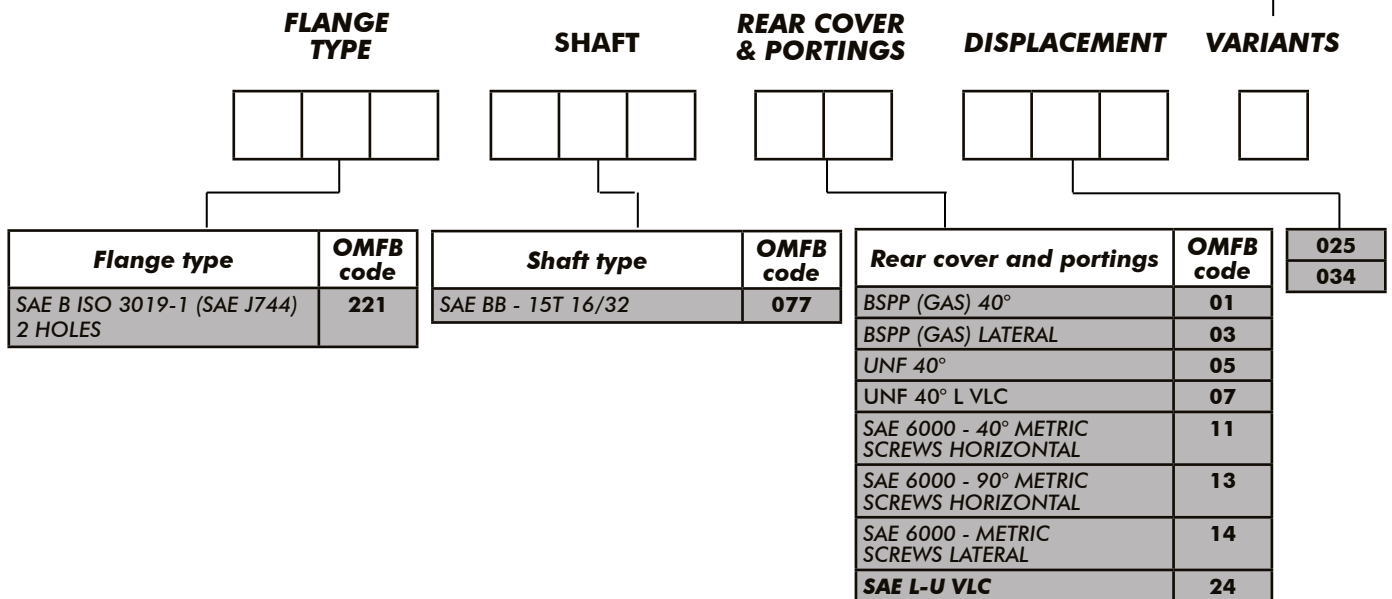

HPM code	Description	
22107701025	Flange	SAE B ISO 3019-1 (SAE J744) 2 HOLES
	Shaft	SAE BB - 15T 16/32
	Portings	BSPP (GAS) 40°
	Displacement	025 cc

**CODING
EXAMPLE**

OVERALL MOTORS DIMENSIONS

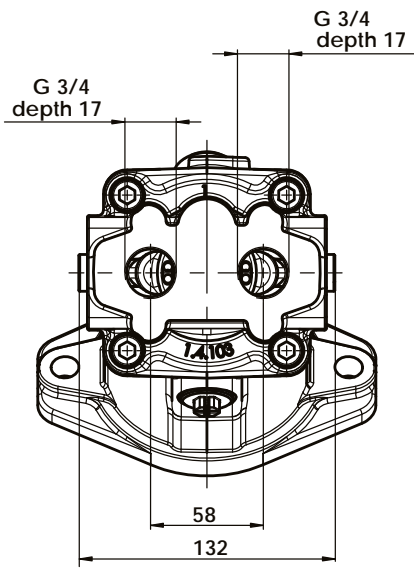
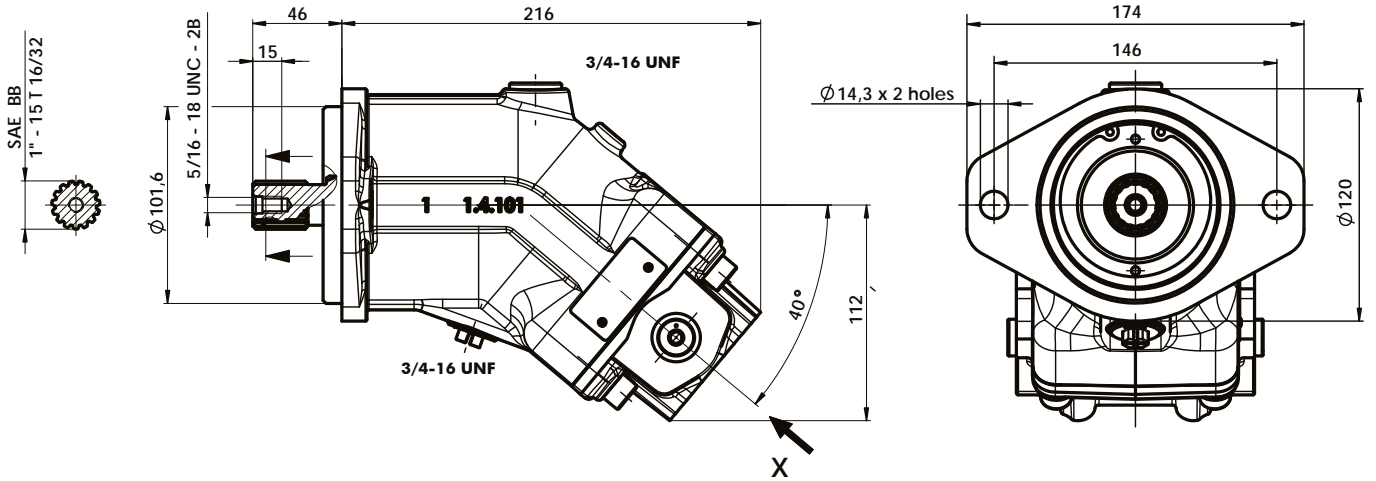

View X
Ports 40° BSP
standard ISO 228

OMFB
Code
01 ●

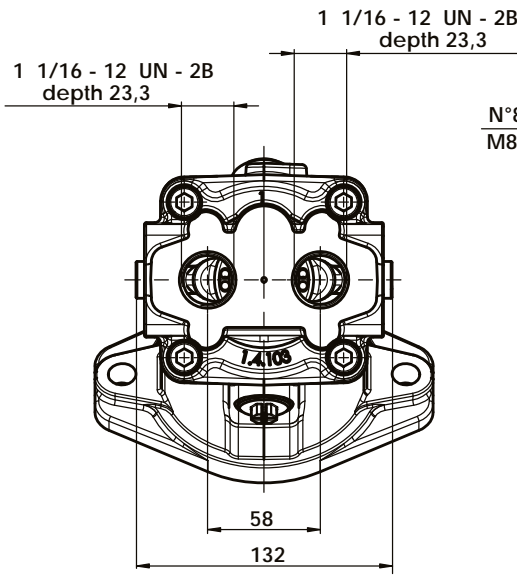

View X
Ports 40° SAE
standard ISO 11926

OMFB
Code
05 ●

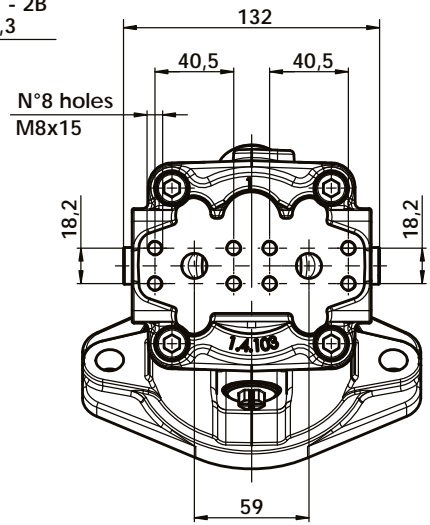

View X
Ports 40°
SAE 6000 psi - 1/2"
standard SAE J518

OMFB
Code
11 ●

OMFB P/N STRUCTURE

FLANGE	SHAFT	PORTS	DISPLACEMENT
221	077	XX ●	XXX

OVERALL MOTORS DIMENSIONS

Codice fascicolo: 997-400-24411

Data: Venerdì 28 settembre 2018

Rev: AL

Codice foglio: 997-244-00011

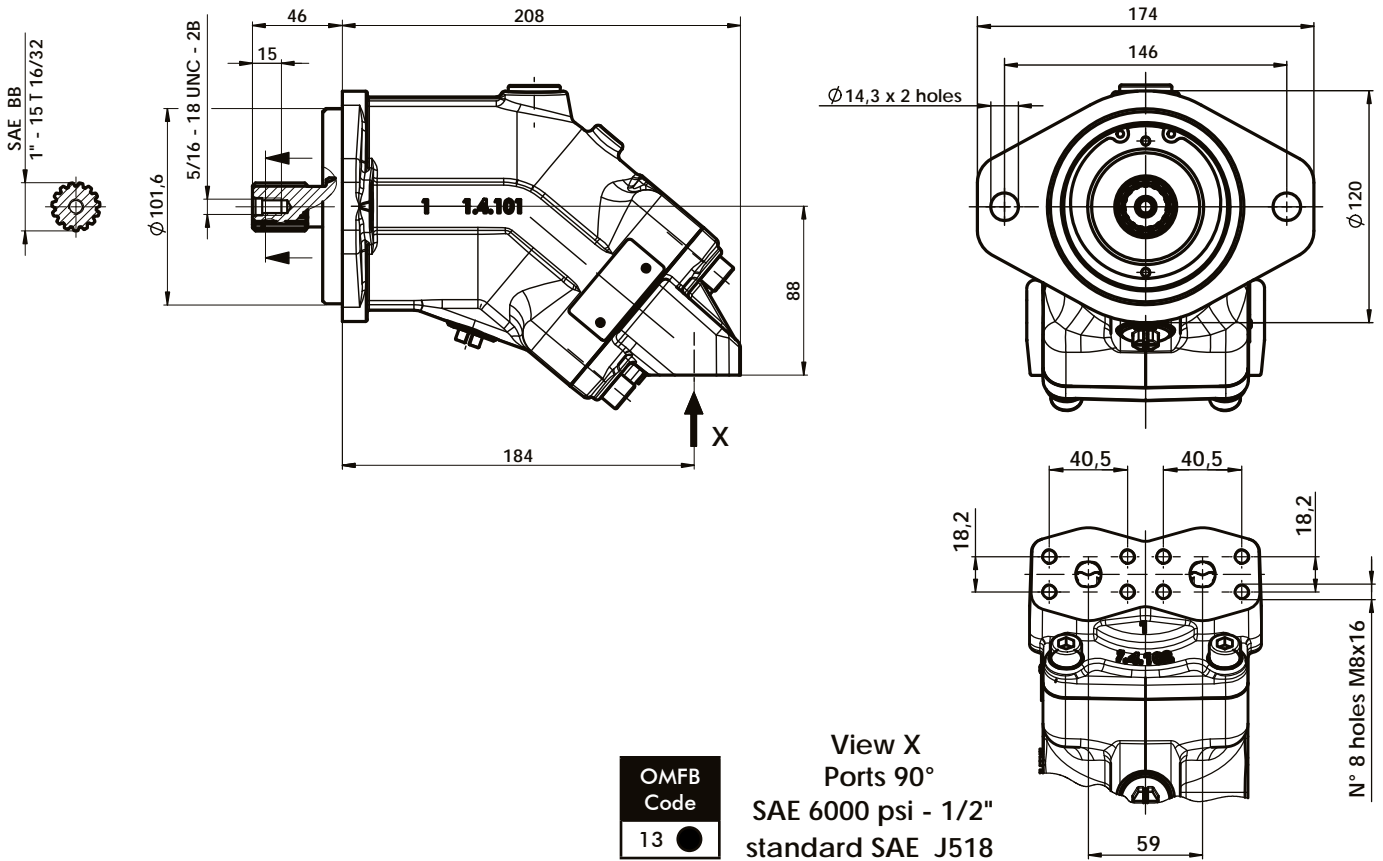
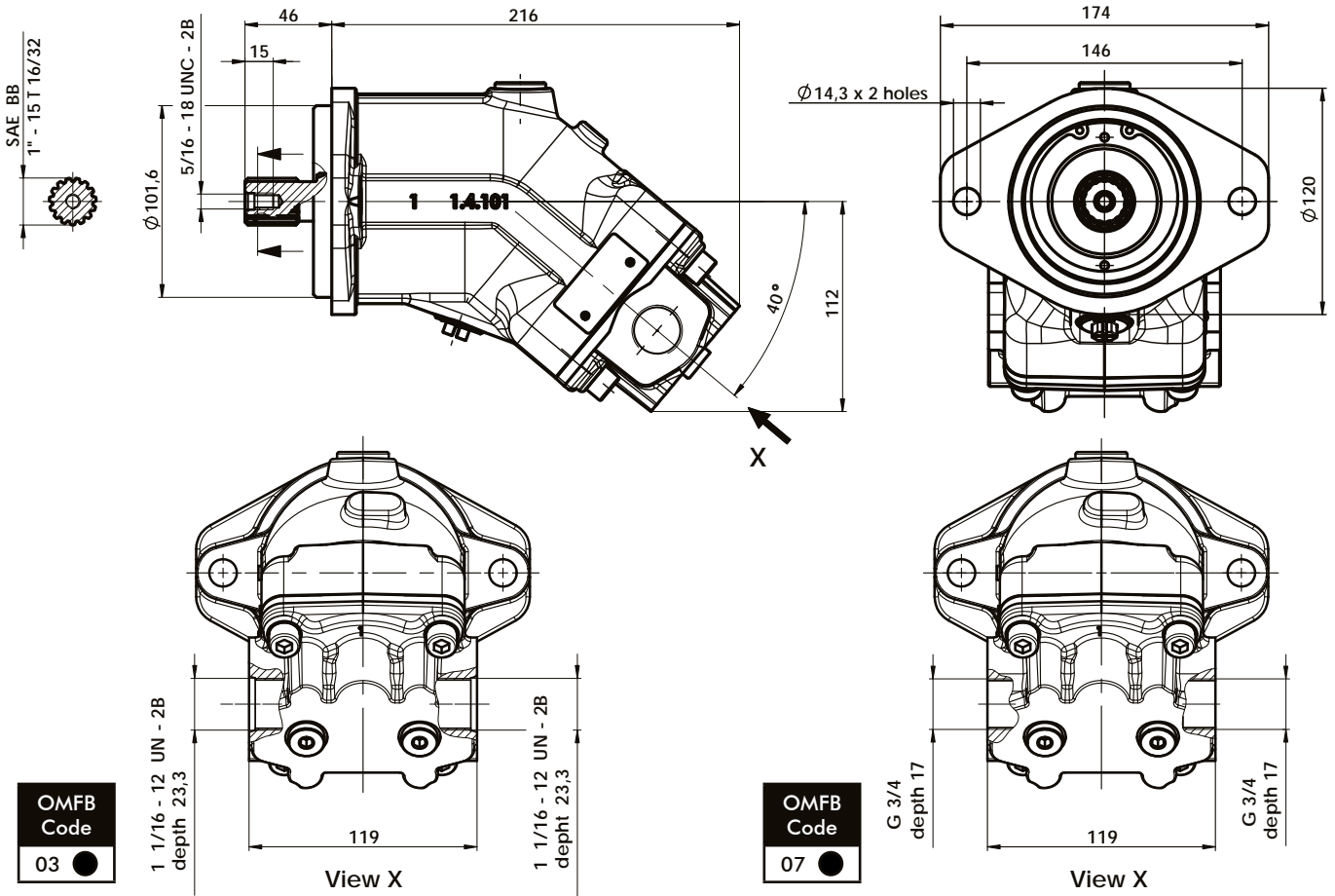

OVERALL MOTORS DIMENSIONS

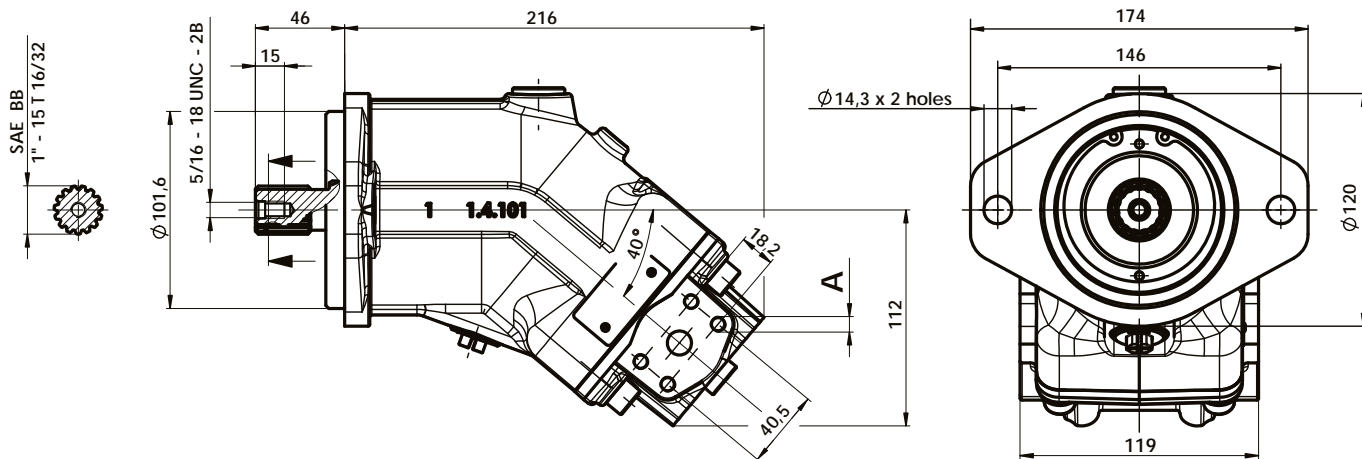

PORTINGS SAE J518-3/4" 6000psi (41,4 MPa) lateral		OMFB code
A	M 8 x15	14 ●
	5/16" UNC	24 ●

Codice fascicolo: 997-400-24411

Data: Venerdì 28 settembre 2018

Rev: AL

Codice foglio: 997-244-00011

BENT AXIS PISTON MOTORS SERIES "HPM" SAE C 4 H. FLANGE

FLANGE Ø 127

HPM2

Codice fascicolo:997-400-24411



SAE FLANGE	ISO FLANGE mm	DISPLACEMENT cm ³	VALVES OFFSET mm	Z (THEET) n°	SENSOR DEPTH mm
SAE B	Ø80	12-17	42	27	18,4
	Ø100	25-34	59		
SAE C	Ø125	40-47 55-64	75	32	
	Ø140	80-91	84	38	
	Ø160	108-130	99		32

P	Motor with speed sensor option
M	Motor complete with selected speed sensor already mounted

(see page 51)

VERSIONS CODING

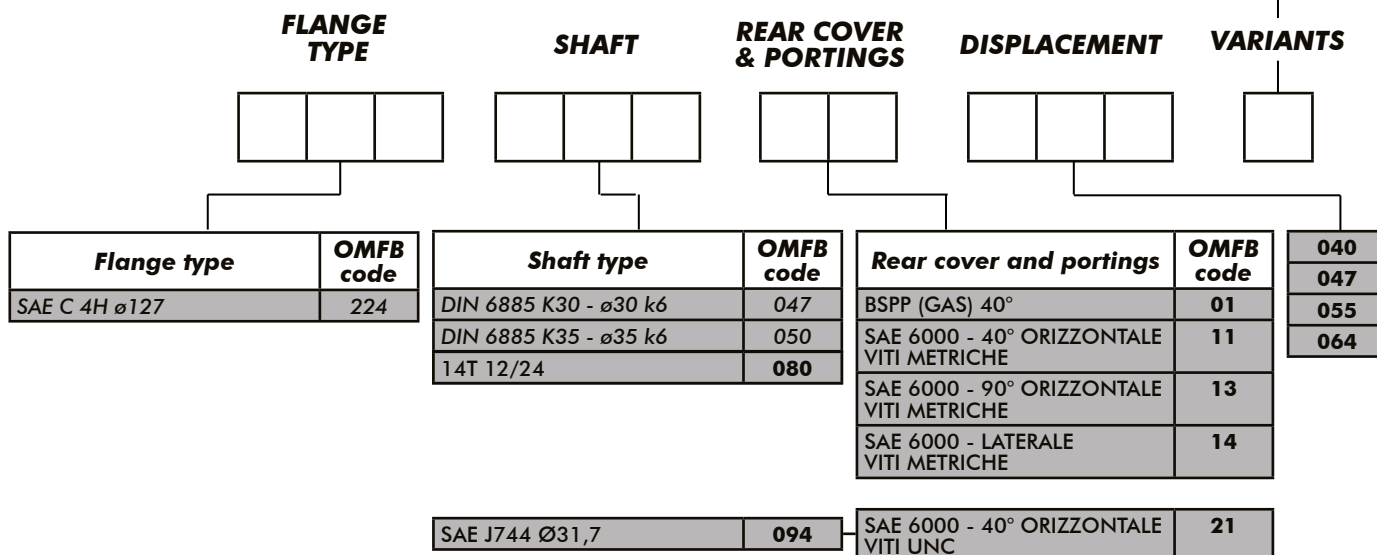

Data: Venerdì 28 settembre 2018

Rev: AL

Codice foglio:997-244-00011

HPM code	Description	
22404701064	Flange	SAE C 4H ø127
	Shaft	DIN 6885 K30 - ø30 k6
	Portings	BSPP (GAS) 40°
	Displacement	064 cc

CODING EXAMPLE

pag.45



O.M.F.B. S.p.A. Hydraulic Components
We reserve the right to make any changes without notice.
Edition 2016.04 No reproduction, however partial, is permitted.
Via Cave, 7/9 25050 Provaglio d'Iseo (Brescia) Italy Tel.: +39.030.9830611
Fax: +39.030.9839207-208 Internet:www.omfb.it e-mail:info@omfb.it

OVERALL MOTORS DIMENSIONS

OVERALL MOTOR DIMENSION WITH 40° REAR COVER

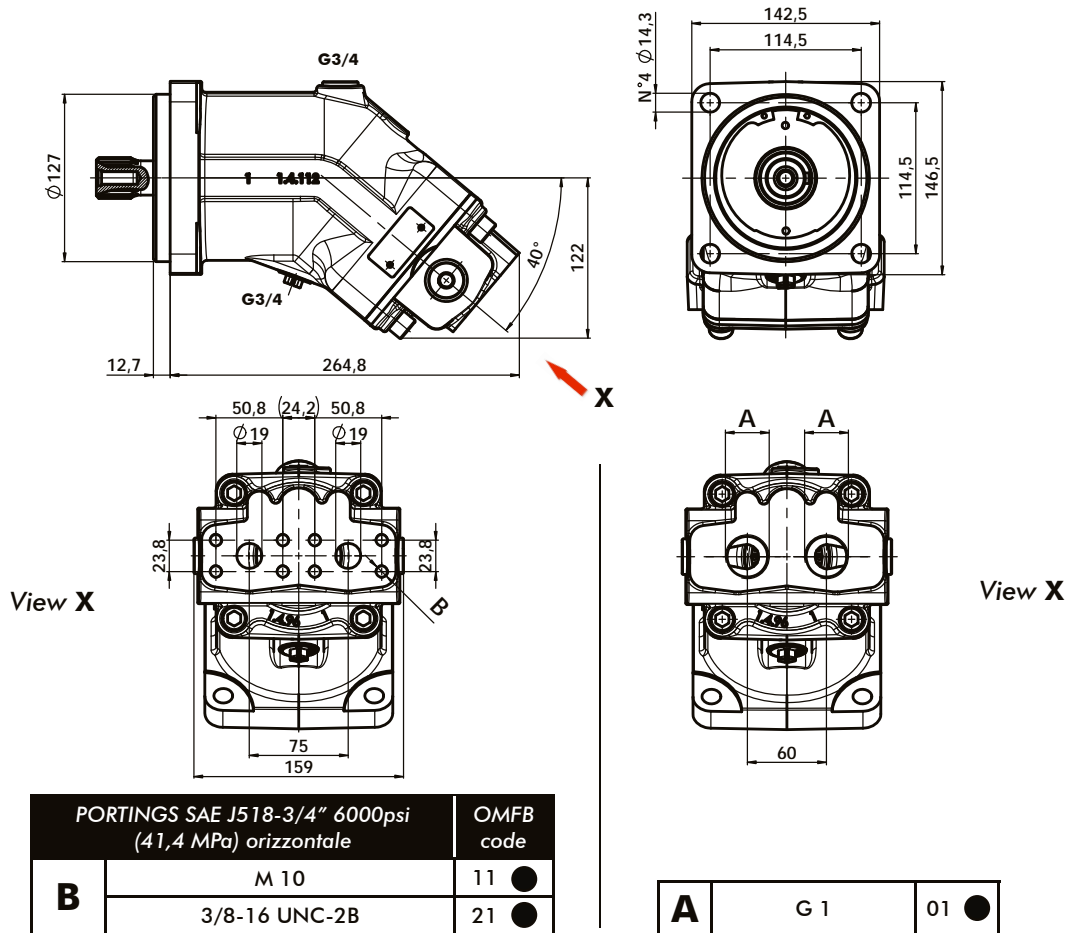

OVERALL MOTOR DIMENSION WITH 90° REAR COVER

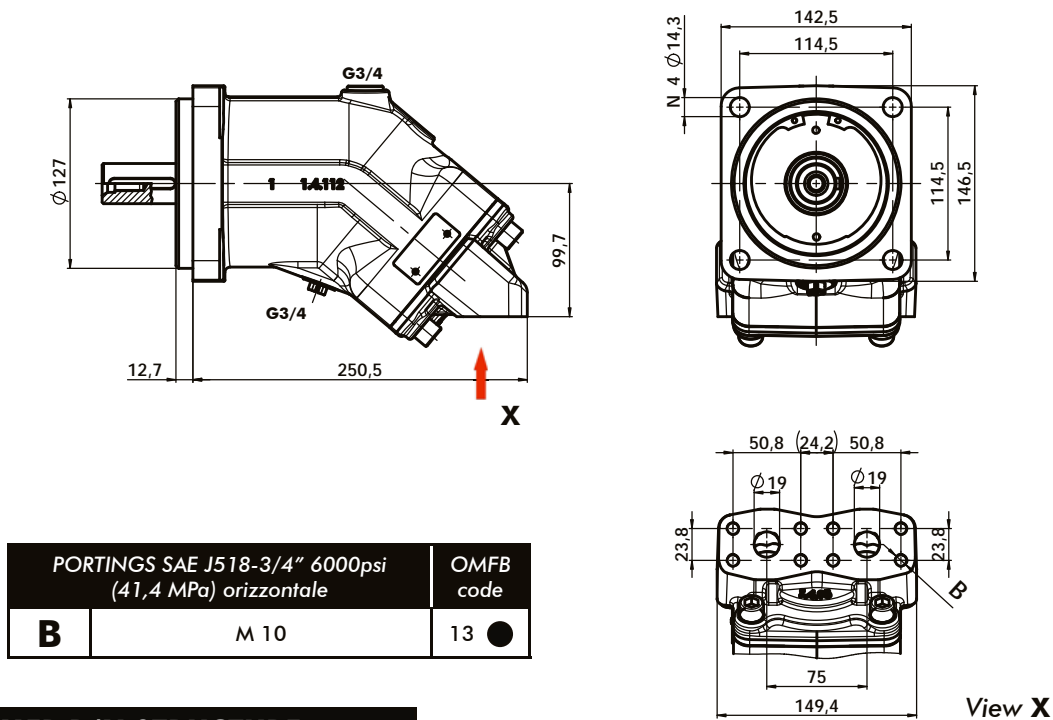

OMFB P/N STRUCTURE

FLANGE	SHAFT	PORTS	DISPLACEMENT
224	xxx ■	xx ●	xxx

OVERALL MOTORS DIMENSIONS

OVERALL MOTOR DIMENSION WITH REAR LATERAL COVER+PANEL

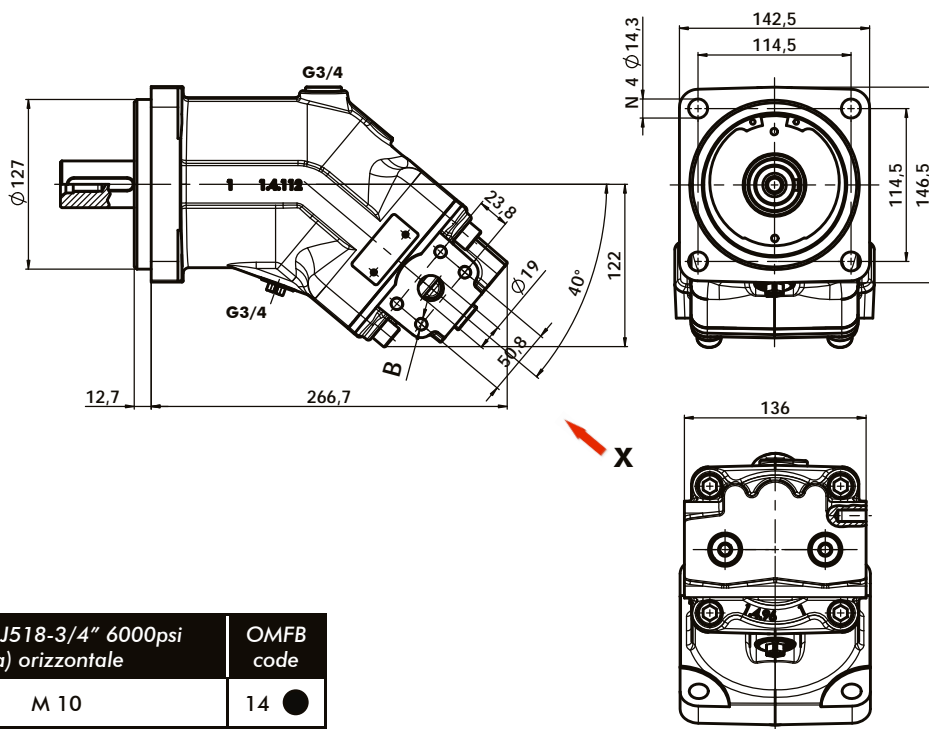

PORTINGS SAE J518-3/4" 6000psi (41,4 MPa) orizzontale		OMFB code
B	M 10	14 ●

SHAFT	OMFB code
K30	047
K35	050
14T 12/24	080
SAE J744 Ø31,7	094

SHAFTS

Displacement		cm ³ /rev	55	64
Working pressure	bar	Max.intermittent	380	330
		Max.continuous	330	280



14T 12/24



Albero 14T 12/24

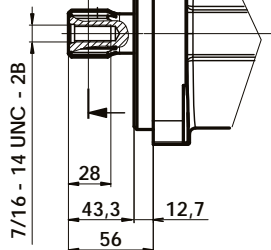

7/16 - 14 UNC - 2B

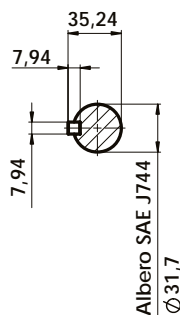

Albero SAE J744 Ø 31,7

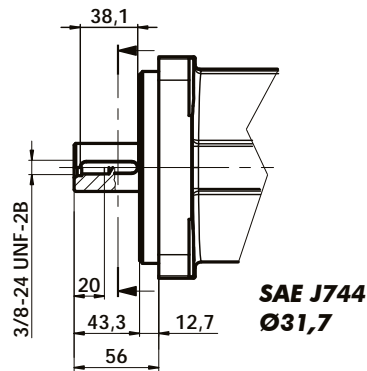

SAE J744 Ø31,7

DIN 6885 K30 - Ø30 k6

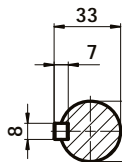

Albero DIN 6885 K30 - Ø 30 k6

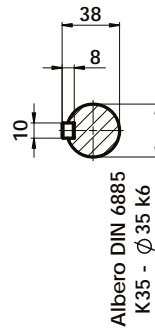
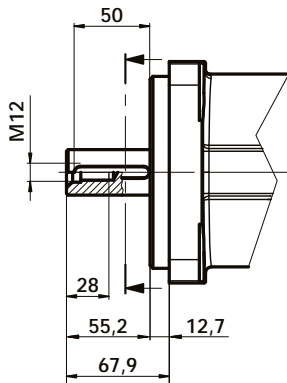

Albero DIN 6885 K35 - Ø 35 k6

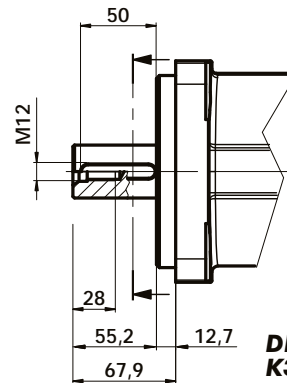

DIN 6885 K35 - Ø35 k6

Displacement		cm ³ /rev	55	64
Working pressure	bar	Max.intermittent	370	320
		Max.continuous	320	270

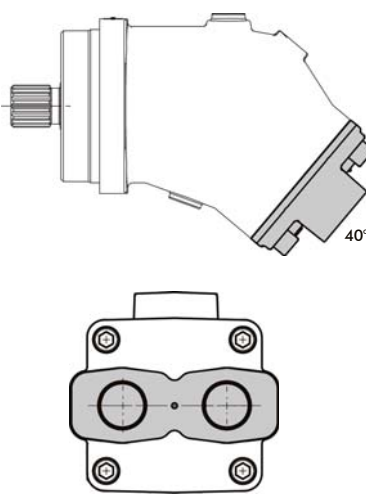
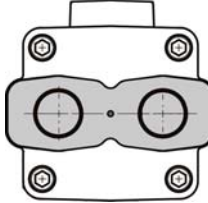
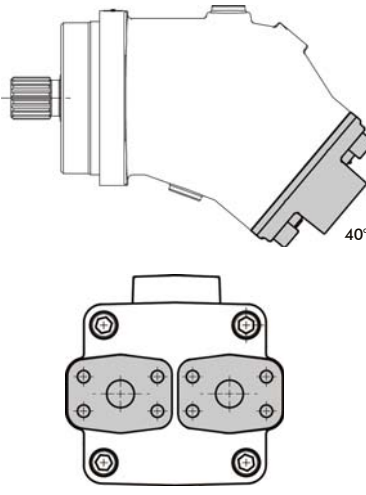
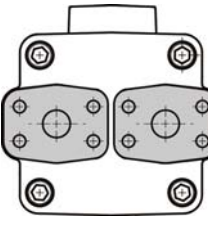
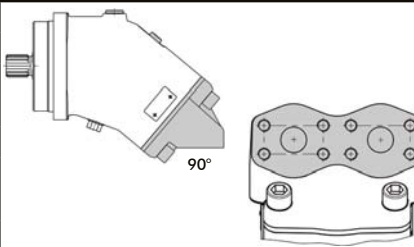
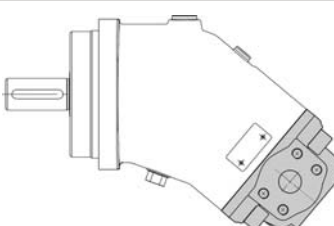

BACK COVER ASSEMBLIES FOR HPM MOTORS

	CODE	DESCRIPTION	
	50004200012	Back cover assemblies for HPM 12cc BSPP (GAS) 40°	Rear cover and portings OMF code 01
	50004200017	Back cover assemblies for HPM 17cc BSPP (GAS) 40°	
	50004200025	Back cover assemblies for HPM 25cc BSPP (GAS) 40°	
	50004200034	Back cover assemblies for HPM 34cc BSPP (GAS) 40°	
	50004200040	Back cover assemblies for HPM 40cc BSPP (GAS) 40°	
	50004200047	Back cover assemblies for HPM 47cc BSPP (GAS) 40°	
	50004200055	Back cover assemblies for HPM 55cc BSPP (GAS) 40°	
	50004200064	Back cover assemblies for HPM 64cc BSPP (GAS) 40°	
	50004201012	Back cover assemblies for HPM 12cc UN 40°	Rear cover and portings OMF code 05
	50004201017	Back cover assemblies for HPM 17cc UN 40°	
	50004201025	Back cover assemblies for HPM 25cc UN 40°	
	50004201034	Back cover assemblies for HPM 34cc UN 40°	
	50004201040	Back cover assemblies for HPM 40cc UN 40°	
	50004201047	Back cover assemblies for HPM 47cc UN 40°	
	50004201055	Back cover assemblies for HPM 55cc UN 40°	
	50004201064	Back cover assemblies for HPM 64cc UN 40°	
	50004202025	Back cover assemblies for HPM 25cc Flange SAE 6000 40° Horizontal-Metric	Rear cover and portings OMF code 11
	50004202034	Back cover assemblies for HPM 34cc Flange SAE 6000 40° Horizontal-Metric	
	50004202040	Back cover assemblies for HPM 40cc Flange SAE 6000 40° Horizontal-Metric	
	50004202047	Back cover assemblies for HPM 47cc Flange SAE 6000 40° Horizontal-Metric	
	50004202055	Back cover assemblies for HPM 55cc Flange SAE 6000 40° Horizontal-Metric	
	50004202064	Back cover assemblies for HPM 64cc Flange SAE 6000 40° Horizontal-Metric	
	50004202080	Back cover assemblies for HPM 80cc Flange SAE 6000 40° Horizontal-Metric	
	50004202091	Back cover assemblies for HPM 91cc Flange SAE 6000 40° Horizontal-Metric	
	50004203025	Back cover assemblies for HPM 25cc Flange SAE 6000 40° Horizontal-UNC	Rear cover and portings OMF code 21
	50004203034	Back cover assemblies for HPM 34cc Flange SAE 6000 40° Horizontal-UNC	
	50004203040	Back cover assemblies for HPM 40cc Flange SAE 6000 40° Horizontal-UNC	
	50004203047	Back cover assemblies for HPM 47cc Flange SAE 6000 40° Horizontal-UNC	
	50004203055	Back cover assemblies for HPM 55cc Flange SAE 6000 40° Horizontal-UNC	
	50004203064	Back cover assemblies for HPM 64cc Flange SAE 6000 40° Horizontal-UNC	
	50004203080	Back cover assemblies for HPM 80cc Flange SAE 6000 40° Horizontal-UNC	
	50004203091	Back cover assemblies for HPM 91cc Flange SAE 6000 40° Horizontal-UNC	
	50004204025	Back cover assemblies for HPM 25cc Flange SAE 6000 90° Horizontal-Metric	Rear cover and portings OMF code 13
	50004204034	Back cover assemblies for HPM 34cc Flange SAE 6000 90° Horizontal-Metric	
	50004204040	Back cover assemblies for HPM 40cc Flange SAE 6000 90° Horizontal-Metric	
	50004204047	Back cover assemblies for HPM 47cc Flange SAE 6000 90° Horizontal-Metric	
	50004204055	Back cover assemblies for HPM 55cc Flange SAE 6000 90° Horizontal-Metric	
	50004204064	Back cover assemblies for HPM 64cc Flange SAE 6000 90° Horizontal-Metric	
	50004204080	Back cover assemblies for HPM 80cc Flange SAE 6000 90° Horizontal-Metric	
	50004204091	Back cover assemblies for HPM 91cc Flange SAE 6000 90° Horizontal-Metric	
	50004205025	Back cover assemblies for HPM 25cc Flange SAE 6000 Lateral-Metric	Rear cover and portings OMF code 14
	50004205034	Back cover assemblies for HPM 34cc Flange SAE 6000 Lateral-Metric	
	50004205040	Back cover assemblies for HPM 40cc Flange SAE 6000 Lateral-Metric	
	50004205047	Back cover assemblies for HPM 47cc Flange SAE 6000 Lateral-Metric	
	50004205055	Back cover assemblies for HPM 55cc Flange SAE 6000 Lateral-Metric	
	50004205064	Back cover assemblies for HPM 64cc Flange SAE 6000 Lateral-Metric	
	50004205080	Back cover assemblies for HPM 80cc Flange SAE 6000 Lateral-Metric	
	50004205091	Back cover assemblies for HPM 91cc Flange SAE 6000 Lateral-Metric	

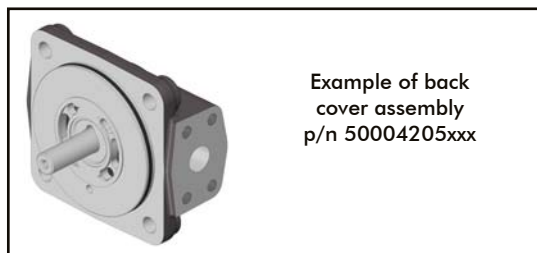

BENT AXIS PISTON MOTORS SERIES HPM SPARE PARTS FLANGE ISO 3019--

Codice fascicolo:997-400-24411

Data: Venerdì 28 settembre 2018

Rev: AL

Codice foglio:997-244-00011

GASKETS KIT

CODE	DESCRIPTION
22190000011	HPM motors gaskets kit - Flange 221 - Shaft 074/091 - Displacements 12/34
22490000015	HPM motors gaskets kit - Flange 224 - Shaft 047/050/080/094 - Displacements 40/47/55/64
22490000024	HPM motors gaskets kit - Flange 224 - Shaft 080 - Displacements 80/90/108
24090000011	HPM motors gaskets kit - Flange 240 - Shaft 008/011/041/044 - Displacements 12/17
24290000017	HPM motors gaskets kit - Flange 242 - Shaft 011/014/044/047 - Displacements 25/34
24490000013	HPM motors gaskets kit - Flange 244 - Shaft 014/020/047/050 - Displacements 40/46/55/64
24690000019	HPM motors gaskets kit - Flange 246 - Shaft 020/023/050/053 - Displacements 80/91
24890000015	HPM motors gaskets kit - Flange 248 - Shaft 023/026/053/056 - Displacements 108/130