

**Low-Pressure In-Line Filters****FNL 1000 · FNL 2000**

In-line mounting · Operating pressure up to 40 bar · Nominal flow rate up to 1450 l/min



Low-Pressure In-Line Filters FNL 1000

**Description****Application**

In the pressure circuits of hydraulic and lubrication systems.

**Performance features***Protection against wear:*

By means of filter elements that meet even the highest demands regarding cleanliness classes.

*Protection against malfunction:*

Through installation near to the control valves or other expensive components. The specific determined flow rate guarantees a closed by-pass valve even at  $v \leq 200 \text{ mm}^2/\text{s}$  (cold start condition).

**Filter elements**

Flow direction from outside to centre. The star-shaped pleating of the filter material results in:

- › large filter surfaces
- › low pressure drop
- › high dirt-holding capacities
- › long service life

**Filter maintenance**

By using a clogging indicator the correct moment for maintenance is stated and guarantees the optimum utilization of the filter life.

**Materials**

Cover:	Aluminium alloy
Filter housing:	Aluminium alloy
Seals:	NBR (FPM on request)
Filter media:	EXAPOR®MAX 2 - inorganic multi-layer microfibre web Paper - cellulose web, impregnated with resin

**Accessories**

Electrical and/or optical clogging indicators are available - optionally with one or two switching points resp. temperature suppression.

Dimensions and technical data see catalogue sheet 60.30.

### Operating pressure

0 ... 16 bar, min.  $3 \times 10^6$  pressure cycles  
Nominal pressure according to DIN 24550

0 ... 40 bar, min.  $10^4$  pressure cycles  
Quasi-static operating pressure

### Permissible pressures for other numbers of cycles

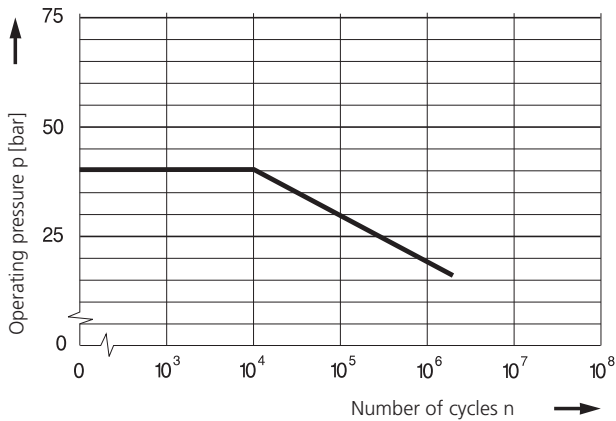

### Nominal flow rate

Up to 1450 l/min (see Selection Chart, column 2).  
The nominal flow rates indicated by ARGO-HYTOS are based on the following features:

- › closed by-pass valve at  $v \leq 200 \text{ mm}^2/\text{s}$
- › element service life > 1000 operating hours at an average fluid contamination of 0,07 g per l/min flow volume
- › flow velocity in the connection lines:  
up to 25 bar  $\leq 4,5 \text{ m/s}$

### Filter fineness

$5 \mu\text{m(c)} \dots 10 \mu\text{m(c)}$   
 $\beta$ -values according to ISO 16889  
(see Selection Chart, column 4 and diagram Dx)

### Dirt-holding capacity

Values in g test dust ISO MTD according to ISO 16889  
(see Selection Chart, column 5)

### Hydraulic fluids

Mineral oil and biodegradable fluids  
(HEEs and HETG, see info-sheet 00.20).

### Temperature range

$-30 \text{ }^\circ\text{C} \dots +100 \text{ }^\circ\text{C}$  (temporary  $-40 \text{ }^\circ\text{C} \dots +120 \text{ }^\circ\text{C}$ )

### Viscosity at nominal flow rate

- › at operating temperature:  $v < 60 \text{ mm}^2/\text{s}$
- › as starting viscosity:  $v_{\text{max}} = 1200 \text{ mm}^2/\text{s}$
- › at initial operation:  
The recommended starting viscosity can be read from the diagram D (pressure drop as a function of the kinematic viscosity) as follows: Find the 70 %  $\Delta p$  of the cracking pressure of the by-pass valve on the vertical axis. Draw a horizontal line so that it intersects the  $\Delta p$  curve at a point. Read this point on the horizontal axis for the viscosity.

### Mounting position

Preferably vertical, filter head at the bottom

### Connection

SAE-flange (3000 psi). Sizes see Selection Chart, line 6  
(other connections on request).  
Standard: connection ports A/B opposed  
Optional: connection port A sidewise, connection port B at the bottom

**Δp-curves for complete filters in Selection Chart, column 3**

**D1** Pressure drop as a function of the **flow volume** at  $v = 35 \text{ mm}^2/\text{s}$  (0 = casing empty)

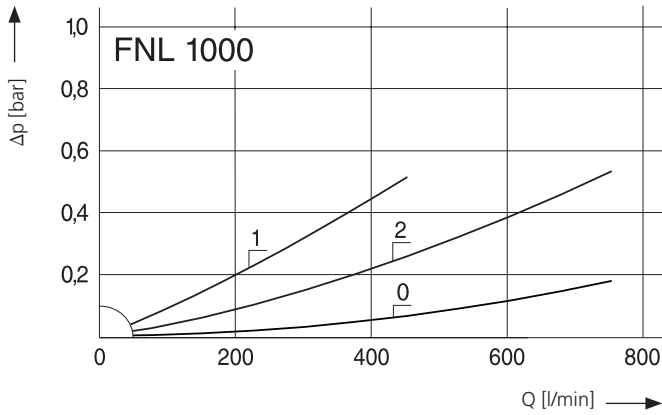

Pressure drop as a function of the **kinematic viscosity** at nominal flow

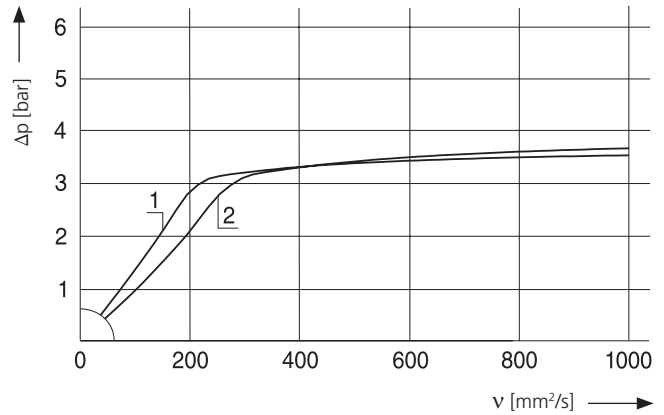

**D2** Pressure drop as a function of the **flow volume** at  $v = 35 \text{ mm}^2/\text{s}$  (0 = casing empty)

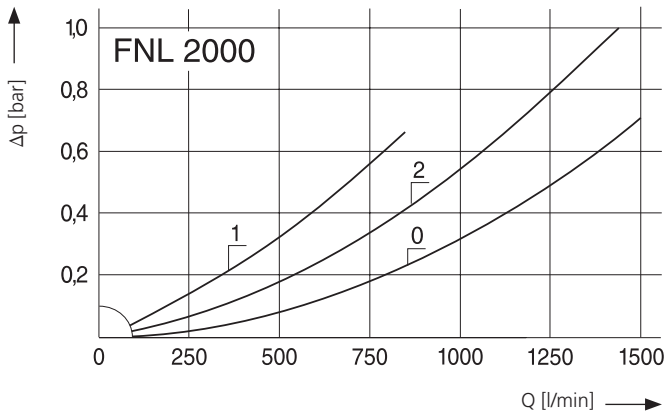

Pressure drop as a function of the **kinematic viscosity** at nominal flow

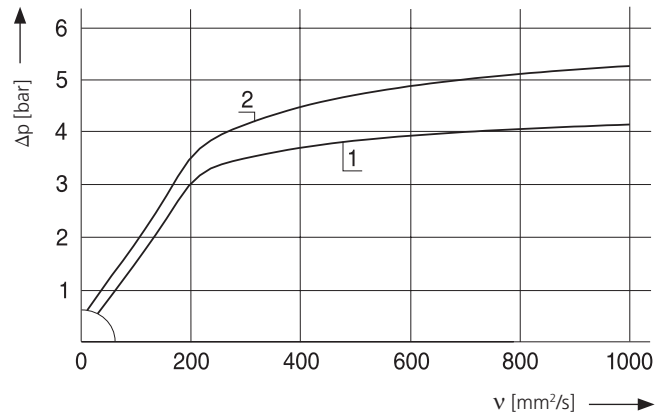

**Filter fineness curves in Selection Chart, column 4**

**Dx** Filtration ratio  $\beta$  as a function of particle size  $x$  obtained by the Multi-Pass-Test according to ISO 16889

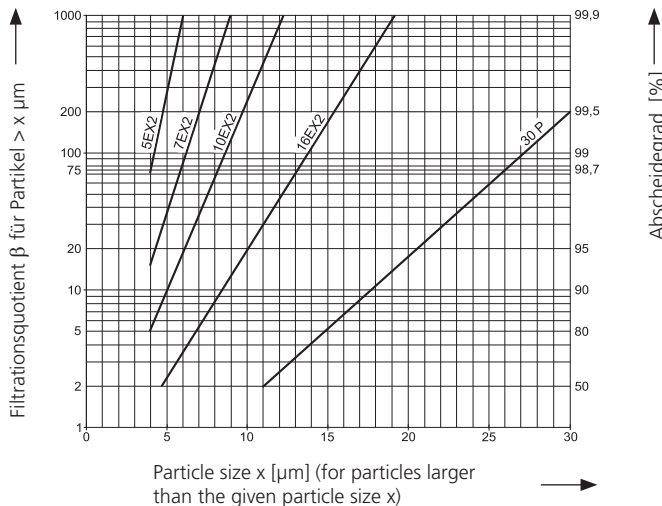

The abbreviations represent the following  $\beta$ -values resp. finenesses:

**For EXAPOR®MAX2 and Paper elements:**

- 5EX2 =  $\beta_{5(c)} = 200$  EXAPOR®MAX 2
- 7EX2 =  $\beta_{7(c)} = 200$  EXAPOR®MAX 2
- 10EX2 =  $\beta_{10(c)} = 200$  EXAPOR®MAX 2
- 16EX2 =  $\beta_{16(c)} = 200$  EXAPOR®MAX 2
- 30P =  $\beta_{30(c)} = 200$  Paper

Based on the structure of the filter media of the 30P paper elements, deviations from the printed curves are quite probable.

For special applications, finenesses differing from these curves are also available by using special composed filter material.

## Selection Chart

Part No.	Nominal flow rate	Pressure drop see diagram <b>D</b> /curve no.	Filter fineness see diagr. <b>Dx</b>	Dirt-holding capacity	Connection A/B	Cracking pressure of bypass	Symbol	Replacement filter element Part No.	Weight	Clogging indicator	Remarks
	l/min		g		bar				kg		
1	2	3	4	5	6	7	8	9	10	11	12
FNL 1000-153	420	<b>D1</b> /1	5EX2	130	SAE 2	3	4	V3.1449-53	21	optional	-
FNL 1000-156	555	<b>D1</b> /2	10EX2	190	SAE 2	3	4	V3.1449-56	21	optional	-
FNL 2000-153	820	<b>D2</b> /1	5EX2	260	SAE 4	3	4	V3.1493-53	28	optional	-
FNL 2000-156	1450	<b>D2</b> /2	10EX2	370	SAE 4	3	4	V3.1493-56	28	optional	-

Optical or electrical indicators are available to monitor the clogging condition of the element. If the indicator should be already mounted onto the filter head use the abbreviation „M“ behind the part number of the indicator. The printed order acknowledgements show both items separately.

**Order example: The Filter FNL 1000-153 has to be supplied with electrical clogging indicator - response pressure 2,5 bar.**

Order description: **FNL 1000-153** / **DG 041-32** **M**  
 Part No. (basic unit) \_\_\_\_\_  
 Clogging indicator \_\_\_\_\_ Mounted

For the appropriate clogging indicator see catalogue sheet 60.30.

### Remarks:

- › The switching pressure of the clogging indicator has always to be lower than the cracking pressure of the by-pass valve (see Selection Chart, column 7).
- › The filters listed in this chart are standard filters. Other designs available on request.

### Optionen:

- › Other filter finenesses on request.
- › Check valve in filter head on request.
- › Connection port A sidewise, connection port B at the bottom (standard: connection ports A/B opposed).

## Dimensions

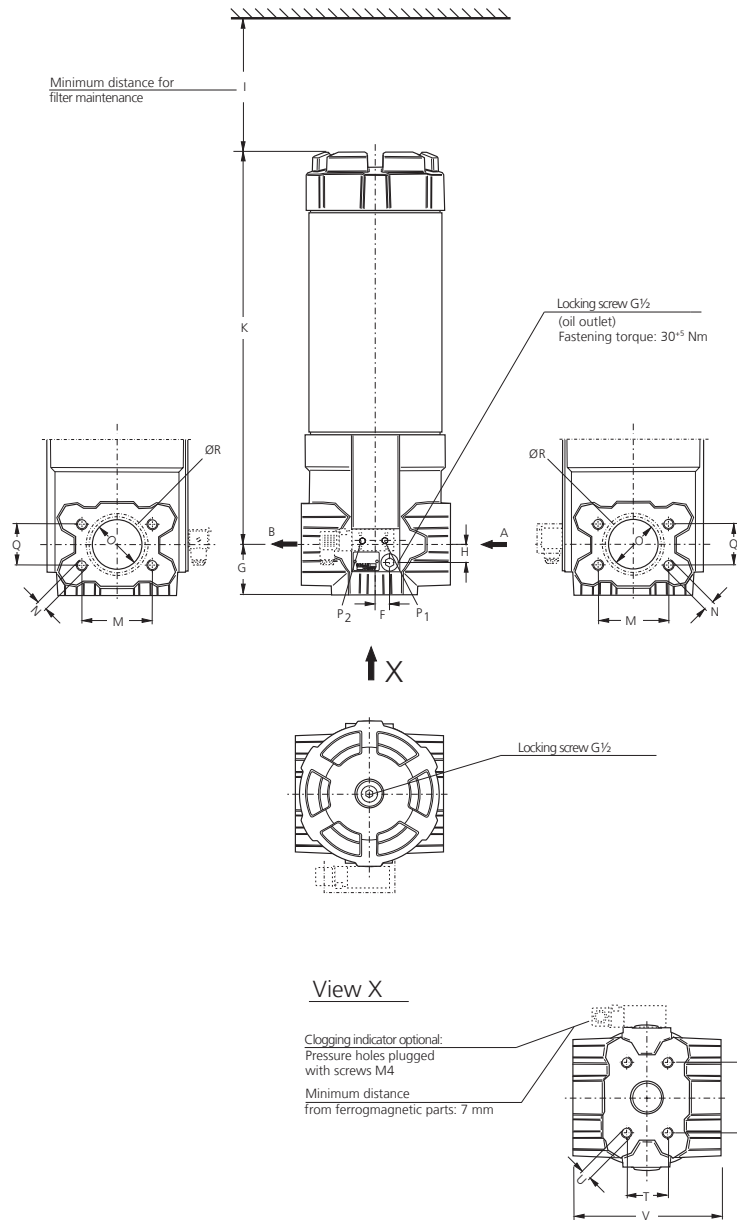

## Measurements

Type	A/B	F	G	H	I	K	M	N	O	Q	R	S	T	U	V
FNL 1000	SAE 2	19	76,5	26,5	450	593	77,8	M12	Ø50	42,6	56-64	130,2	77,8	M16	224
FNL 2000	SAE 4	19	76,5	26,5	890	1033	130,2	M16	Ø100	77,8	110-118	130,2	77,8	M16	224

## Symbols

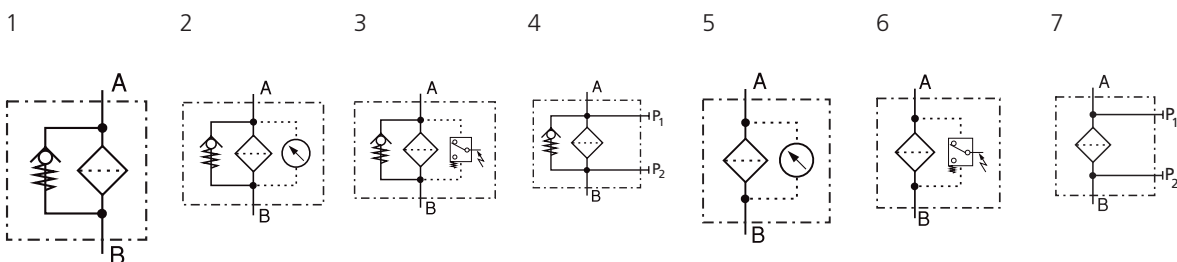

## Spare Parts

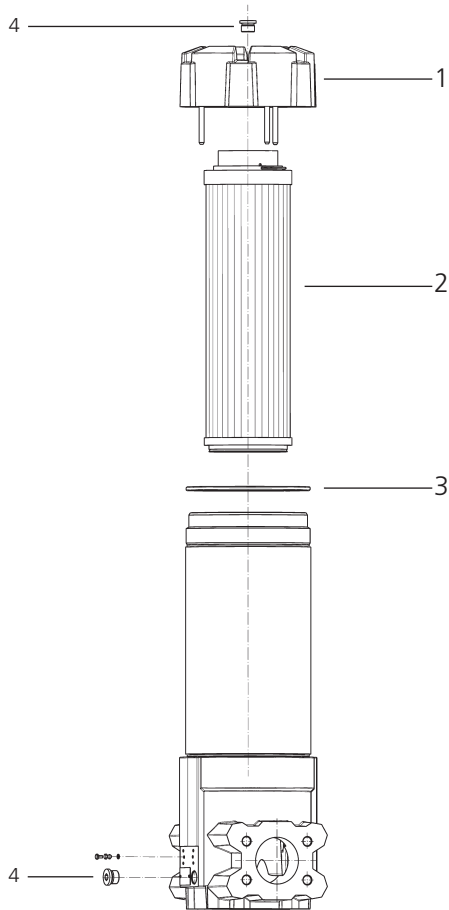

Pos.	Designation	Part No.
1	Cover (complete)	FNL 1000.1200
2	Filter element	see Chart / col. 9
3	O-ring	N007.1905
4	Locking screw	SV 0620.08

The functions of the complete filters as well as the outstanding features of the filter elements assured by ARGO-HYTOS can only be guaranteed if original ARGO-HYTOS spare parts are used.

## Quality Assurance

### Quality management according to DIN EN ISO 9001

To ensure constant quality in production and operation, ARGO-HYTOS filter elements undergo strict controls and tests according to the following ISO standards:

ISO 2941	Verification of collapse/burst pressure rating
ISO 2942	Verification of fabrication integrity (Bubble Point Test)
ISO 2943	Verification of material compatibility with fluids
ISO 3968	Evaluation of pressure drop versus flow characteristics
ISO 16889	Multi-Pass-Test (evaluation of filter fineness and dirt-holding capacity)
ISO 23181	Determination of resistance to flow fatigue using high viscosity fluid

**Before release into the series production the filter casing is tested for fatigue strength in our pressure pulse test rig. Various quality controls during the production process guarantee the leakfree function and solidity of our filters.**

Illustrations may sometimes differ from the original. ARGO-HYTOS is not responsible for any unintentional mistake in this specification sheet.