

SPECIFICATIONS:

- MODEL NUMBER:** 8000-991-236
- PUMP DESIGN:** Positive Displacement 3 Chamber Diaphragm Pump
- CHECK VALVE:** (1-Way Operation) Prevents Reverse Flow
- CAM:** 2.0 Degree
- MOTOR:** Permanent Magnet, P/N 11-124-10, Thermally Protected
- VOLTAGE:** 24 VDC Nominal
- PRESSURE SWITCH:** Adjustable Shut-Off (Range 40-60 PSI)
Factory Set @ 60 PSI, Turn On 40 PSI±5 PSI
- LIQUID TEMPERATURE:** 180 Degrees Fahrenheit (82 Degrees Centigrade) Max.
- PRIME:** Self-Priming Up To 5 Ft. Vertical,
Max. Inlet Pressure 30 PSI (2.1 Bar)
- PORTS:** 3/8"-18 NPT Female
- MATERIAL OF CONSTRUCTION:**
 - PLASTICS-** Nylon
 - VALVES-** EPDM
 - DIAPHRAGM-** Santoprene
 - FASTENERS-** Stainless Steel
- NET WEIGHT:** 3.8 Lbs (1.7 Kg)
- DUTY CYCLE:** Intermittent (See Temperature Rise Chart)
- TYPICAL APPLICATIONS:** R. O. Booster Pump

DIMENSIONS:

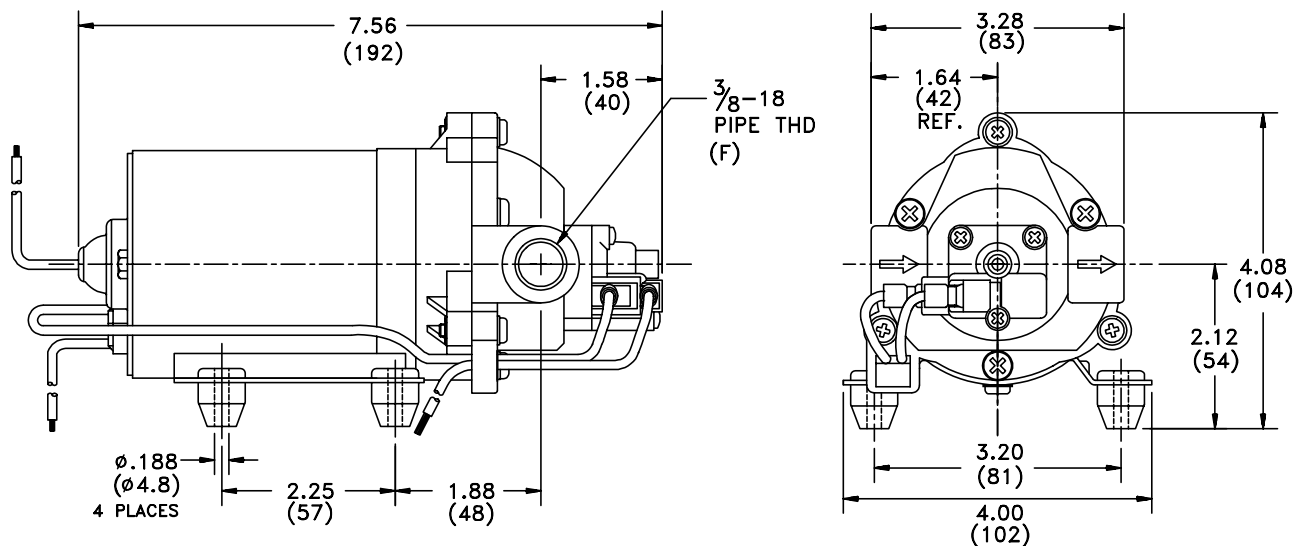

TEMPERATURE RISE

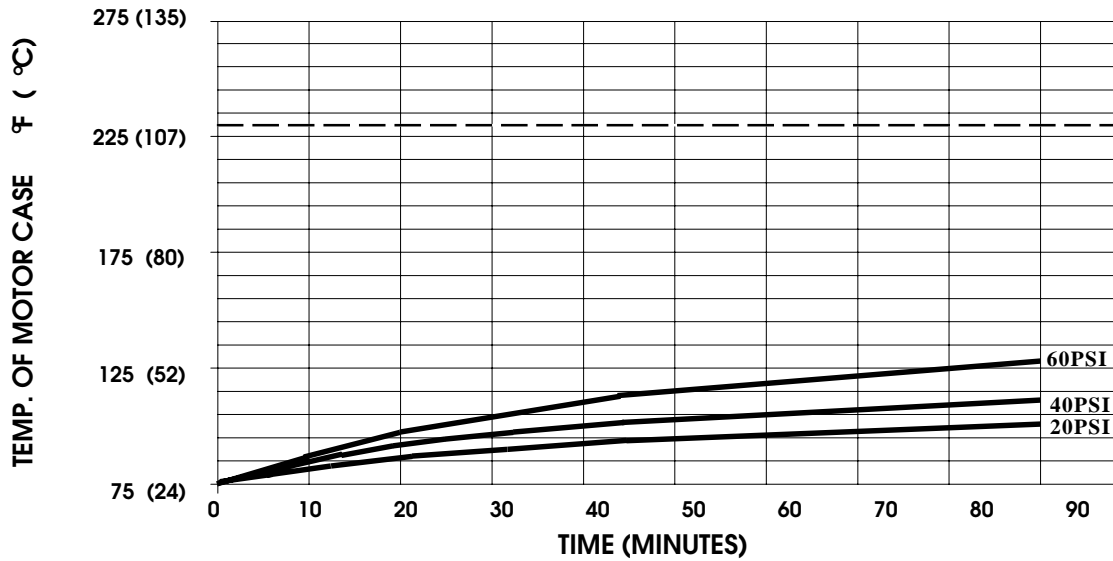

THIS GRAPH IS FOR USE AS A DESIGN GUIDE. IT IS BASED ON RUNNING CONTINUOUSLY WITH AN AMBIENT TEMPERATURE OF 75° F IN STILL AIR. THE THERMAL BREAKER WILL OPEN WHEN THE CASE TEMPERATURE REACHES 230° F.

[----- TRIP POINT OF THERMAL PROTECTOR]

TYPICAL PERFORMANCE

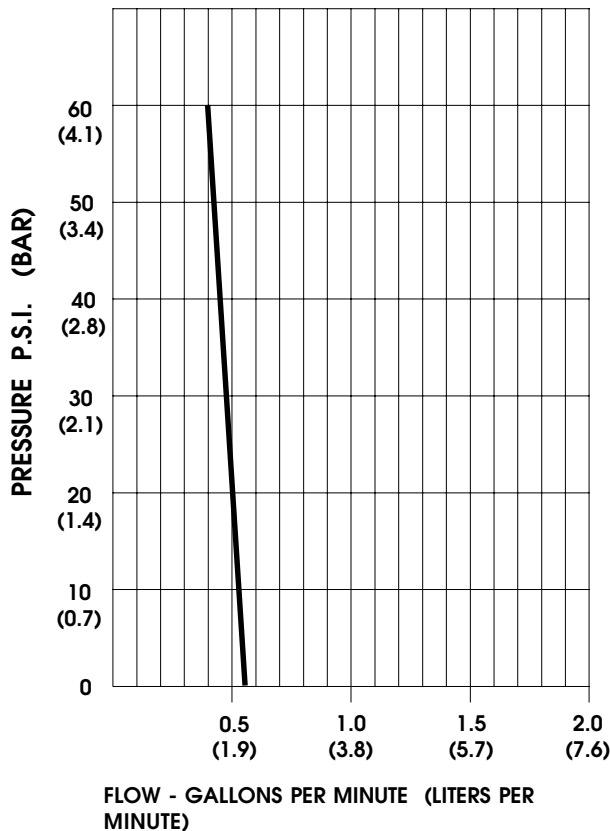

PRESSURE (PSI)	FLOW (GPM/LIT)	RPM MIN/MAX	CURRENT (AMPS)	VOLTAGE (VOLTS)
OPEN	0.56/2.1	1240/1270	0.45	24 VDC
10	0.54/2.0	1205/1235	0.54	"
20	0.52/1.9	1170/1180	0.66	"
30	0.49/1.8	1110/1125	0.80	"
40	0.45/1.7	1065/1085	0.92	"
50	0.43/1.6	1020/1050	1.03	"
60	0.39/1.5	970/1015	1.13	"

-SPECIFICATIONS SUBJECT TO CHANGE WITHOUT NOTICE.

-ALL DATA BASED ON TESTING WITH WATER AT AMBIENT TEMPERATURE.