

HYDRAULIC MOTORS MSY

MSY is the new hydraulic motor in a family of "disc valve" series which has dimensions and mounting data the same as at hydraulic motors type MS.

This motor is described with 15÷20% higher technical data-max. Torque and max. Pressure drop, thereby higher power. This makes it suitable for vehicles with greater loads and speed drop.



CONTENTS

Specification data	25
Function diagrams	26÷28
Dimensions and mounting	13÷14
Wheel motor	15
Motor with Drum Brake - MSYB	16
Shaft extensions	17
Permissible shaft loads	18
Function diagram for MSYB	18
Permissible Shaft Seal Pressure.....	19
Dimensions and mounting- MSYS, V	29
Internal Spline data	30
Order code	30

OPTIONS

- » Model- Disc valve, roll-gerotor
- » Flange and wheel mount
- » Short motor
- » Side and rear ports
- » Shafts- straight, splined and tapered
- » Other special features

GENERAL

Displacement, [cm ³ /rev.]	200 ÷ 474,6
Max. Speed, [RPM]	155 ÷ 375
Max. Torque, [daNm]	56,6 ÷ 91
Max. Output, [kW]	9 ÷ 18,1
Max. Pressure Drop, [bar]	140 ÷ 200
Max. Oil Flow, [l/min]	75
Min. Speed, [RPM]	5 ÷ 8
Permissible Shaft Loads, [daN]	P _a = 500
Pressure fluid	Mineral based- HLP(DIN 51524) or HM(ISO 6743/4)
Temperature range, [°C]	-30 ÷ 90
Optimal Viscosity range, [mm ² /s]	20 ÷ 75
Filtration	ISO code 20/16 (Min. recommended fluid filtration of 25 micron)

Oil flow in drain line

Pressure drop (bar)	Viscosity (mm ² /s)	Oil flow in drain line (l/min)
140	20	1,5
	35	1
210	20	3
	35	2

Pressure Losses

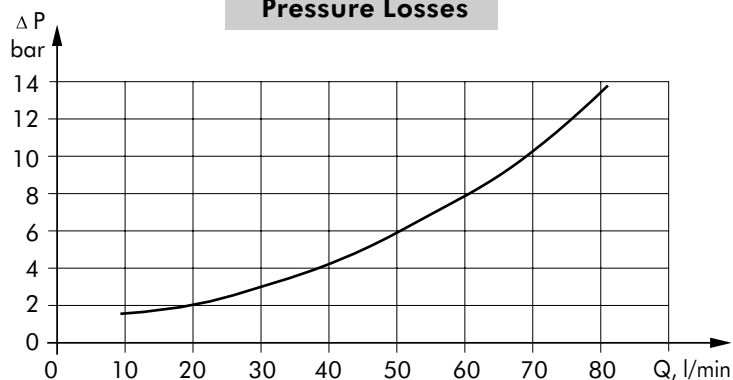

SPECIFICATION DATA FOR MSY

Type	MSY 200	MSY 250	MSY 315	MSY 400	MSY 475	
Displacement [cm ³ /rev.]	200	250	314,9	397	474,6	
Max. Speed, [RPM]	cont.	375	300	240	185	155
	Int.*	450	360	285	225	185
Max. Torque [daNm]	cont.	56,6	70,8	90,0	90,0	91
	Int.*	64,5	80,6	96,0	97,0	96
	peak**	65	80,6	108	110	100
Max. Output [kW]	cont.	18,1	18,0	17	11,0	9,0
	int.*	24,0	23,8	20,2	12	11,0
Max. Pressure Drop [bar]	cont.	200	200	200	160	140
	Int.*	225	225	220	175	150
	peak**	225	225	225	200	175
Max. Oil Flow [l/min]	cont.	75	75	75	75	75
	Int.*	90	90	90	90	90
Max. Inlet Pressure [bar]	cont.	210	210	210	210	210
	Int.*	250	250	250	250	250
	peak**	300	300	300	300	300
Max. Return Pressure with Drain Line [bar]	cont.	140	140	140	140	140
	Int.*	175	175	175	175	175
	peak**	210	210	210	210	210
Max. Starting Pressure with Unloaded Shaft, [bar]	8	8	8	8	8	
Min. Starting Torque [daNm]	at max. press. drop cont.	46,2	58,0	73,8	72,0	47
	at max. press. drop Int.*	50,7	63,6	79,2	78,7	55
Min. Speed***, [RPM]	6	6	5	5	5	
Weight, [kg]	MSY (F)	11,2	11,7	12,4	13,3	14,4
For Rear Ports	MSYW	11,7	12,2	12,9	13,8	15,0
+0,4 kg	MSYQ	11,6	12,1	12,8	13,7	14,9

* Intermittent operation: the permissible values may occur for max. 10% of every minute.

** Peak load: the permissible values may occur for max. 1% of every minute.

*** For speeds of 5 RPM lower than given, consult factory or your regional manager.

- 1) Intermittent speed and intermittent pressure must not occur simultaneously.
- 2) Recommended filtration is per ISO cleanliness code 20/16. A nominal filtration of 25 micron or better.
- 3) Recommend using a premium quality, anti-wear type mineral based hydraulic oil HLP(DIN51524) or HM (ISO 6743/4). If using synthetic fluids consult the factory for alternative seal materials.
- 4) Recommended minimum oil viscosity 13 mm²/s at operating temperatures.
- 5) Recommended maximum system operating temperature is 82°C.
- 6) To assure optimum motor life fill with fluid prior to loading and run at moderate load and speed for 10-15 minutes.

FUNCTION DIAGRAMS

MSY 200

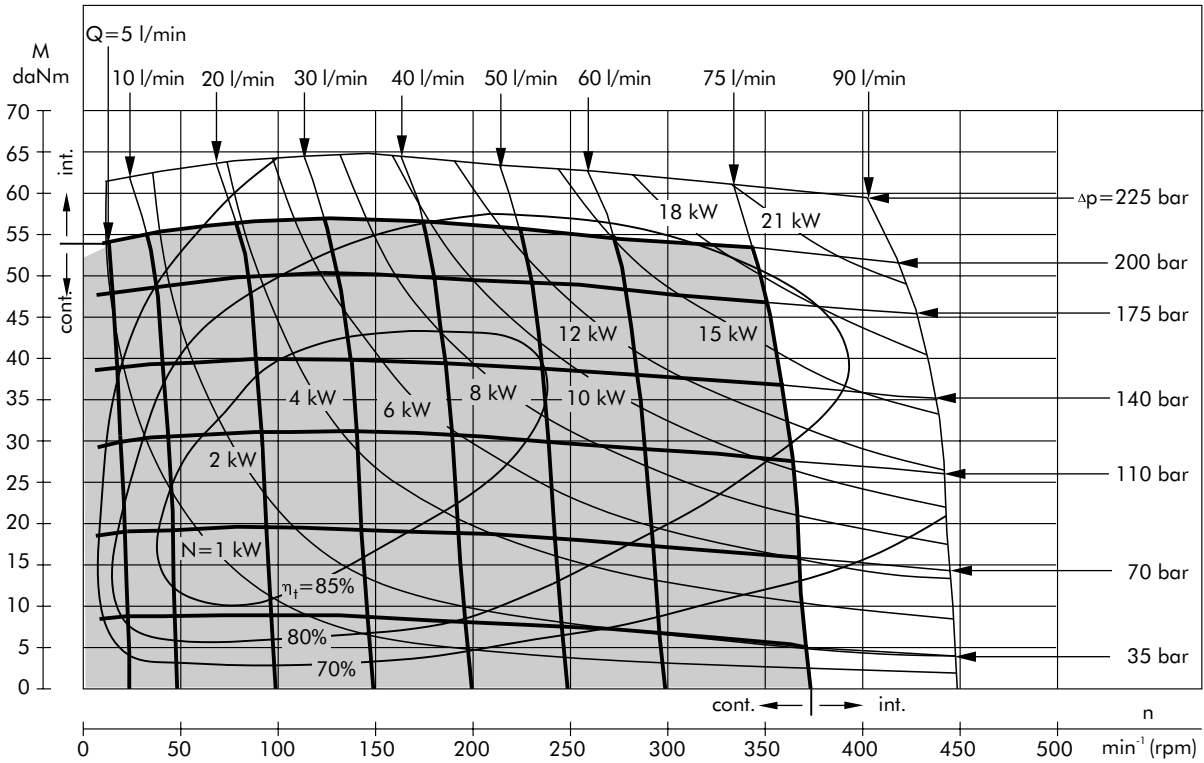

MSY 250

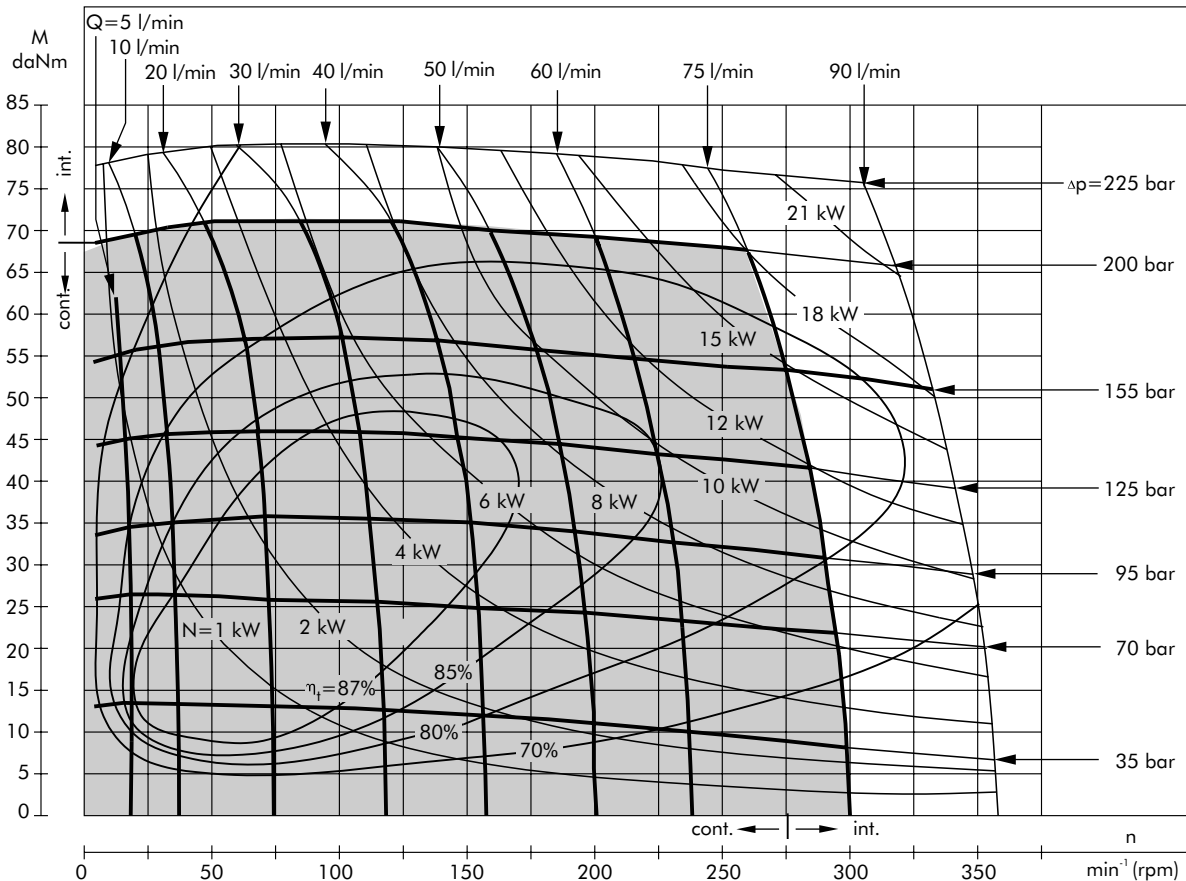

The function diagrams data was collected at back pressure 5 ÷ 10 bar and oil with viscosity of 32 mm²/s at 50° C.

FUNCTION DIAGRAMS

MSY 315

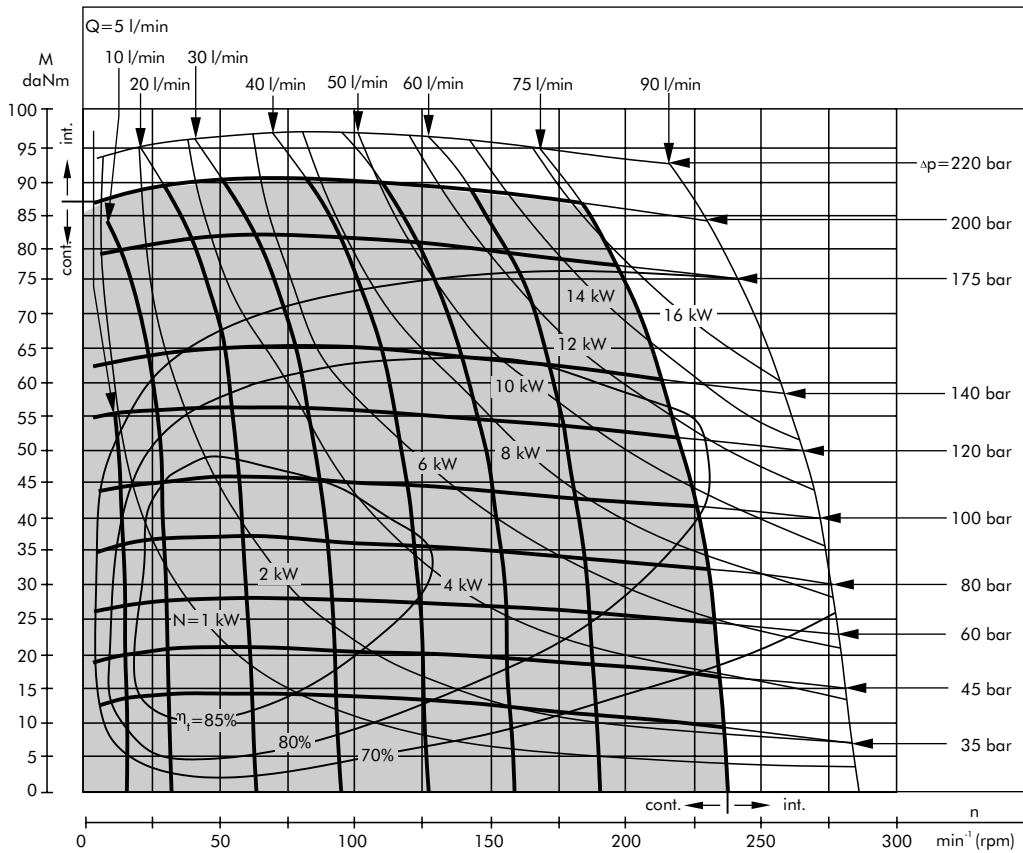

MSY 400

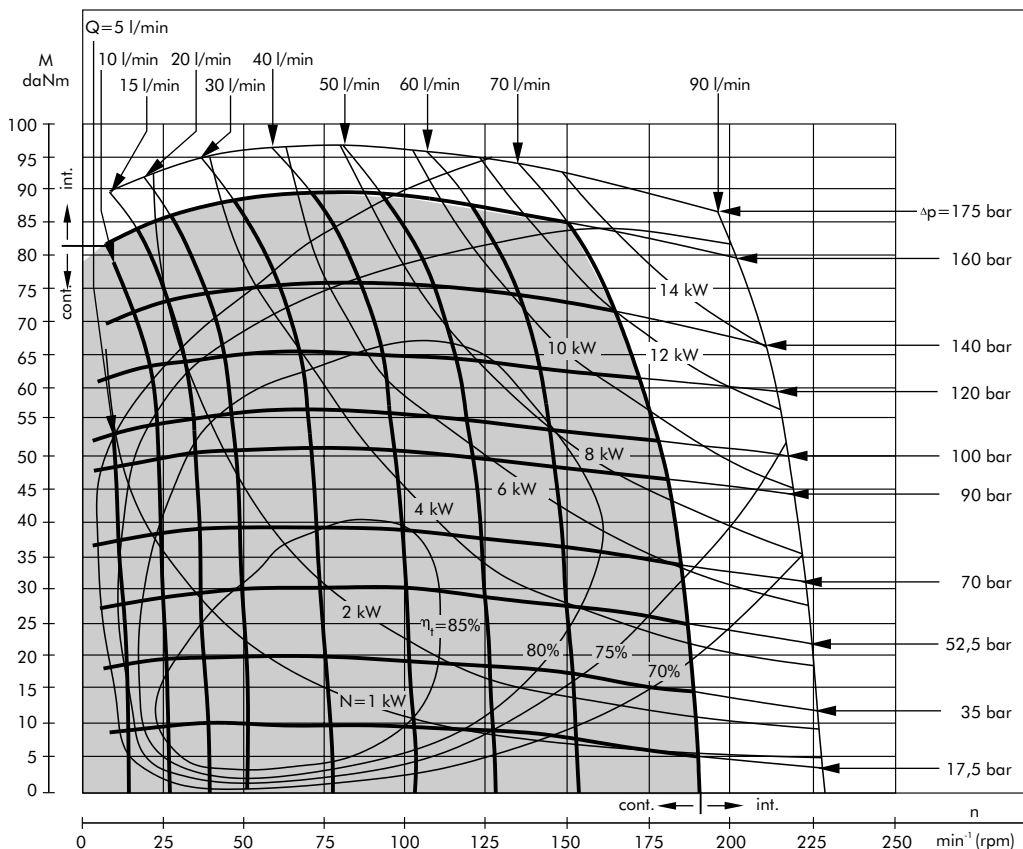

The function diagrams data was collected at back pressure 5 ÷ 10 bar and oil with viscosity of 32 mm²/s at 50° C.

FUNCTION DIAGRAMS

MSY 475

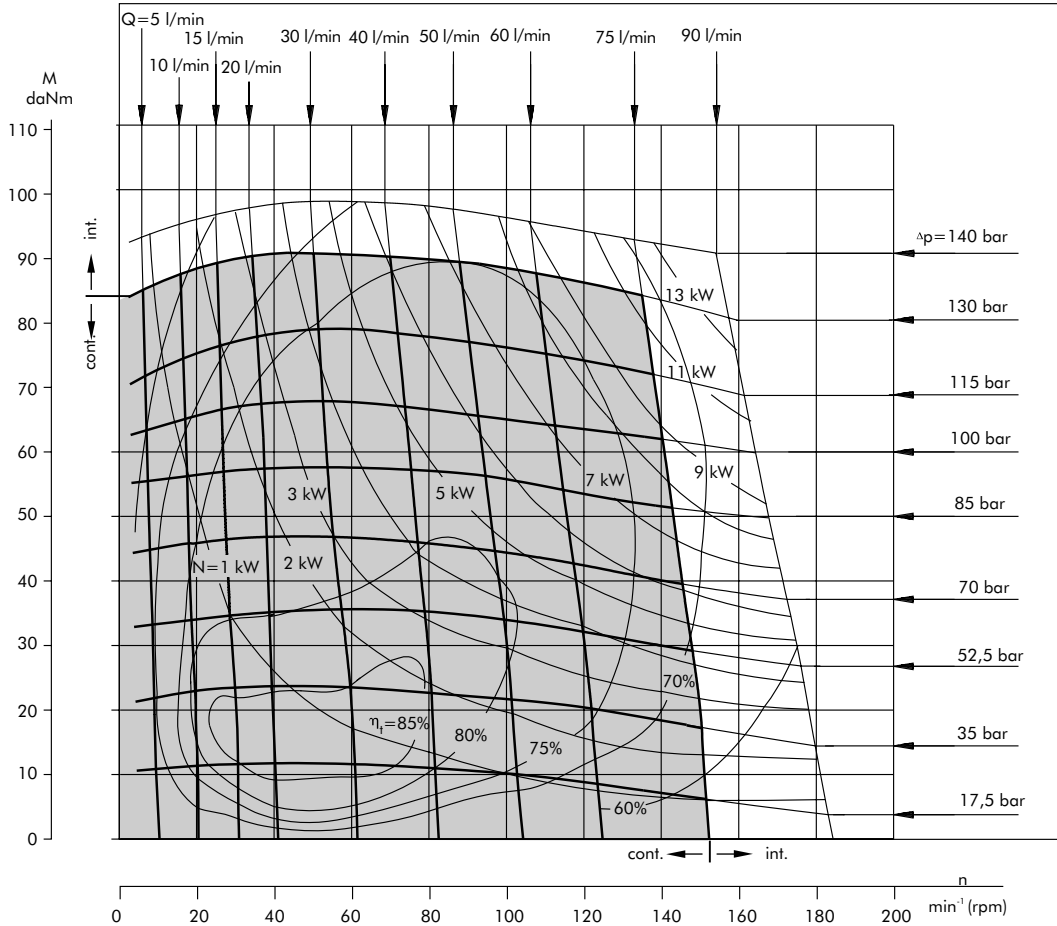

The function diagrams data was collected at back pressure 5 ÷ 10 bar and oil with viscosity of 32 mm²/s at 50° C.

The dimensions, mounting data, shaft extensions and permissible shaft loads are the same as at hydraulic motors type MS except following below.

DIMENSIONS OF THE ATTACHED COMPONENT

For MSYS

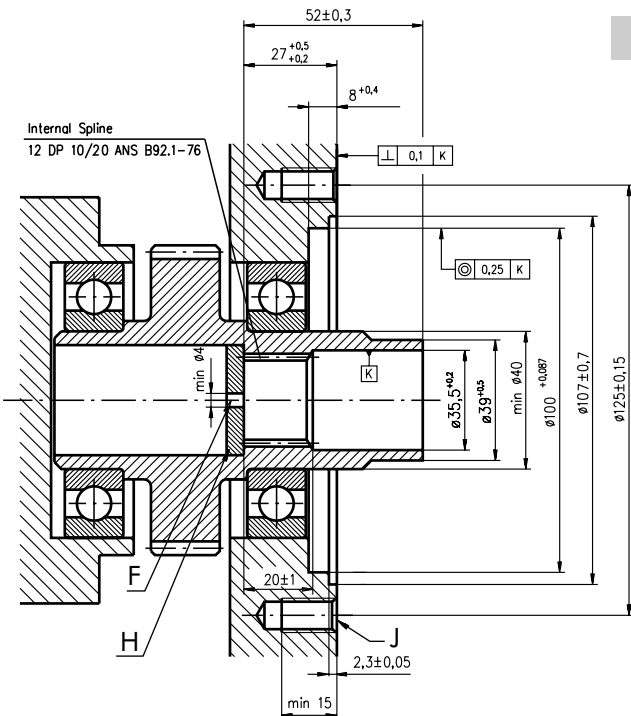

F: Oil circulation hole
H: Hardened stop plate

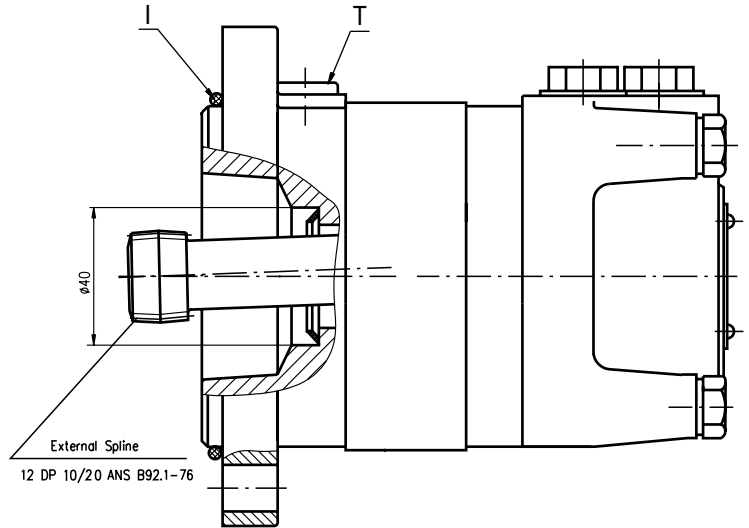

I: O- Ring 100x3mm
J: 4xM10-16 mm depth, 90°
T: Drain connection G1/4 or M14x1,5

For MSYV

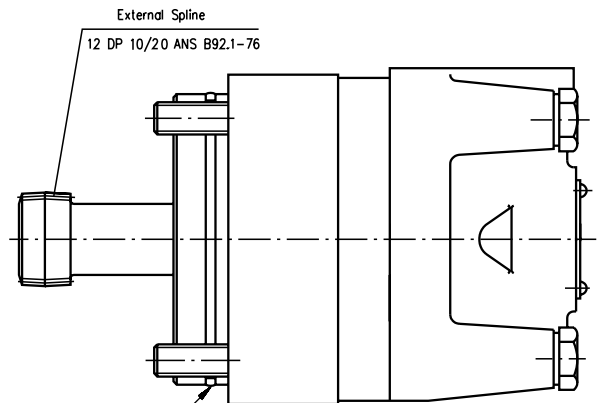
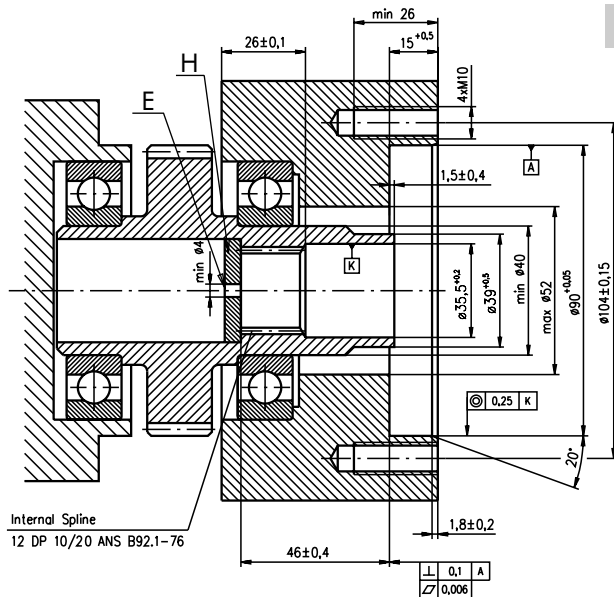

E: External drain hole
H: Hardened stop plate
I: O- Ring 85x2mm

DRAIN CONNECTION

A drain line ought to be used when pressure in the return line can exceed the permissible pressure. It can be connected:

- For MSYS at the drain port of the motor;
- For MSYV at the drain connection of the attached component. The maximum pressure in the drain line is limited by the attached component and its shaft seal.

The drain line must be possible for oil to flow freely between motor and attached component and must be led to the tank. The maximum pressure in the drain line is limited by the attached component and its seal.

INTERNAL SPLINE DATA FOR THE ATTACHED COMPONENT

Standard 12 DP 10/20 ANSI B92.1-1976, class 5
[$m=2.54$; corrected $x.m=+0,4$]

Fillet Root Side Fit		mm
Number of Teeth	z	12
Diametral Pitch	DP	10/20
Pressure Angle		30°
Pitch Dia.	D	30,48
Major Dia.	D _{ri}	33,2 ^{+0,2}
Minor Dia.	D _i	27,8 ^{+0,1}
Space Width [Circular]	L _o	4,45 ^{+0,071} _{+0,026}
Fillet Radius	R _{min}	0,2
Max. Measurement between Pin	L	23,39 ^{+0,17} _{+0,06}
Pin Dia.	d	4,835±0,001

Above are when hardened

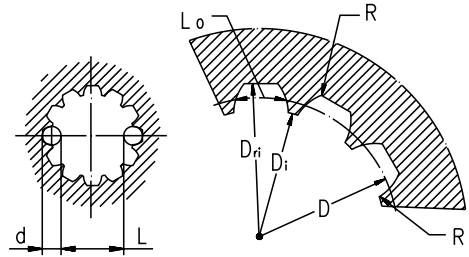

Hardening Specification:
HV=750±50 on the surface
HV=560 at 0,7±0,2 mm case depth
Material 20 MoCr4 EN 10084 or better

ORDER CODE

	1	2	3	4	5	6	7	8	9
MSY									

Pos. 1 - Mounting Flange

omit - SAE A-4 mount, four holes

- A** - SAE A-2 mount, two holes
- F** - Magneto mount, four holes
- Q** - Square mount, four holes
- B** - Motor with drum brake
- S** - Short mount
- V** - Very short mount
- W** - Wheel mount

Pos. 2 - Port type

omit - Side ports

- E** - Rear ports

Pos. 3 - Displacement code

- 200** - 200,0 [cm³/rev]
- 250** - 250,0 [cm³/rev]
- 315** - 314,9 [cm³/rev]
- 400** - 397,0 [cm³/rev]
- 475** - 474,5 [cm³/rev]

Pos. 4 - Shaft Extensions*

omit - for **B**, **S** and **V** mounting flange

- C** - ø32 straight, Parallel key A10x8x45 DIN6885
- K** - ø35 tapered 1:10, Parallel key B6x6x20 DIN6885
- SL** - ø34,85 p.t.o. DIN 9611 Form 1
- SH** - ø1¼" splined 14T ANSI B92.1-1976

Pos. 5 - Shaft Seal Version (see page 19)

- omit - Low pressure seal
- U** - High pressure seal

Pos. 6 - Ports

- omit - BSPP (ISO 228)
- M** - Metric (ISO 262)

Pos. 7 - Actuating Direction**

- /R** - Right
- /L** - Left

Pos. 8 - Special Features (see page 53)

Pos. 9 - Design Series

- omit - Factory specified

NOTES:

* The permissible output torque for shafts must not be exceeded!

** Only for MSYB

The hydraulic motors are manganophosphatized as standard.