

HYDRAULIC MOTORS MVM

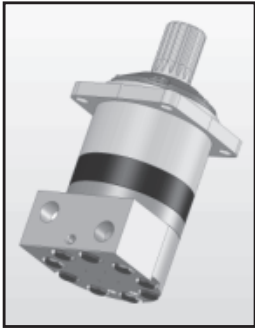

APPLICATION

- » Conveyors
- » Metal working machines
- » Agricultural machines
- » Road building machines
- » Mining machinery
- » Food industries
- » Special vehicles
- » Plastic and rubber machinery etc.

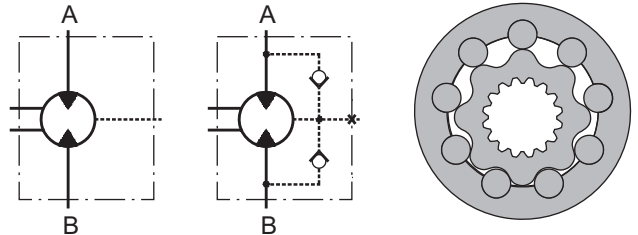

CONTENTS

Specification data.....	38
Function diagrams.....	39÷41
Permissible shaft loads.....	41
Dimensions and mounting MVM.....	42
Dimensions and mounting MVMC.....	42
Mounting flanges.....	43
Port types.....	43
Shaft extensions.....	44
Permissible shaft seal pressure.....	45
Order code.....	45

OPTIONS

- » Model - Disc valve, roll-gerotor
- » Flange with wheel mount
- » Short motor
- » Side ports
- » Shafts - straight, splined and tapered
- » BSPP ports Metric, SAE and BSPP ports
- » Other special features

EXCELLENCE

- » High torque and pressure drop
- » High inlet pressure
- » High starting torque
- » Improved efficiency at high pressure drop and frequent reversing
- » Smooth operation at low speed
- » High radial and axial bearing capacity

GENERAL

Max. Displacement, in ³ /rev [cm ³ /rev]	48.91 [801,8]
Max. Speed, [RPM]	763
Max. Torque, lb-in [daNm]	cont.: 22920 [259] int.: 30090 [340]
Max. Output, HP [kW]	150 [112]
Max. Pressure Drop, PSI [bar]	cont.: 3630 [250] int.: 5080 [350]
Max. Oil Flow, GPM [lpm]	63.4 [240]
Min. Speed, [RPM]	5
Permissible Shaft Loads, lbs [daN]	Pa=3370 [1500]
Pressure fluid	Mineral based- HLP(DIN 51524) or HM(ISO 6743/4)
Temperature range, °F [°C]	-40÷284 [-40÷140]
Optimal Viscosity range, SUS [mm²/s]	98÷347 [20÷75]
Filtration	ISO code 20/16 (Min. recommended fluid filtration of 25 microns)

Oil flow in drain line

Pressure drop PSI [bar]	Viscosity SUS [mm ² /s]	Oil flow in drain line GPM [lpm]
2030 [140]	98 [20]	.793 [3]
	164 [35]	.528 [2]
3045 [210]	98 [20]	.1.585 [6]
	164 [35]	1.057 [4]

Pressure Losses

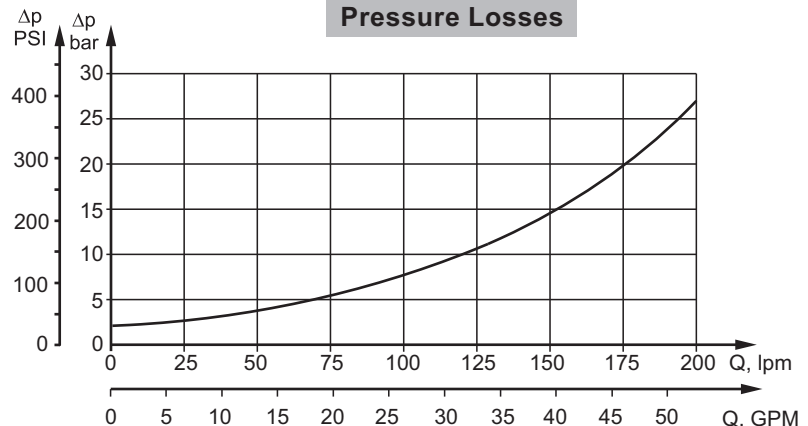

SPECIFICATION DATA

Type		MVM 315	MVM 400	MVM 500	MVM 630	MVM 800
Displacement, in ³ /rev [cm ³ /rev]		19.19 [314,5]	24.5 [400,9]	30.5 [499,6]	38.38 [629,1]	48.91 [801,8]
Max. Speed, [RPM]	cont.	636	500	400	315	250
	Int.*	763	600	480	380	300
Max. Torque lb-in [daNm]	cont.	10180 [115]	12745 [144]	15930 [180]	20090 [227]	22920 [259]
	Int.*	14160 [160]	17700 [200]	23010 [260]	27440 [310]	30090 [340]
	peak**	15930 [180]	20355 [230]	25315 [286]	31860 [360]	35580 [402]
Max. Output HP [kW]	cont.	90 [67]	90 [67]	90 [67]	90 [67]	90 [67]
	int.*	150 [112]	150 [112]	150 [112]	150 [112]	150 [112]
Max. Pressure Drop PSI [bar]	cont.	3630 [250]	3630 [250]	3630 [250]	3630 [250]	3263 [225]
	Int.*	5080 [350]	5080 [350]	5080 [350]	5080 [350]	4350 [300]
	peak**	5800 [400]	5800 [400]	5800 [400]	5800 [400]	5080 [350]
Max. Oil Flow GPM [lpm]	cont.	52.8 [200]	52.8 [200]	52.8 [200]	52.8 [200]	52.8 [200]
	Int.*	63.4 [240]	63.4 [240]	63.4 [240]	63.4 [240]	63.4 [240]
Max. Inlet Pressure PSI [bar]	cont.	3915 [270]	3915 [270]	3915 [270]	3915 [270]	3915 [270]
	Int.*	5365 [370]	5365 [370]	5365 [370]	5365 [370]	5365 [370]
	peak**	6090 [420]	6090 [420]	6090 [420]	6090 [420]	6090 [420]
Max. Return Pressure with Drain Line PSI [bar]	cont.	2030 [140]	2030 [140]	2030 [140]	2030 [140]	2030 [140]
	Int.*	2540 [175]	2540 [175]	2540 [175]	2540 [175]	2540 [175]
	peak**	3045 [210]	3045 [210]	3045 [210]	3045 [210]	3045 [210]
Max. Starting Pressure with Unloaded Shaft, PSI [bar]		70 [5]	70 [5]	70 [5]	70 [5]	70 [5]
Min. Starting Torque, lb-in [daNm]		8140 [92]	10180 [115]	12745 [144]	15930 [180]	18145 [205]
Min. Speed***, [RPM]		10	6	8	6	5
Weight, lb [kg]	MVM	91 [41.3]	93 [42,1]	95 [43]	98 [44,5]	101.4 [46]
	MVMC	96.6 [43,8]	99 [44,9]	101 [45,8]	106.5 [48,3]	111.1 [50,4]

* Intermittent operation: the permissible values may occur for max. 10% of every minute.

** Peak load: the permissible values may occur for max. 1% of every minute.

*** For speeds lower than given, consult factory or your regional manager.

1. Intermittent speed and intermittent pressure drop must not occur simultaneously.
2. Recommended filtration is per ISO cleanliness code 20/16. A nominal filtration of 25 micron or better.
3. Recommend using a premium quality, anti-wear type mineral based hydraulic oil HLP(DIN51524) or HM (ISO 6743/4).
If using synthetic fluids consult the factory for alternative seal materials.
4. Recommended minimum oil viscosity 70 SUS [13 mm²/s] at 122°F [50°C].
5. Recommended maximum system operating temperature is 180°F [82°C].
6. To assure optimum motor life fill with fluid prior to loading and run at moderate load and speed for 10-15 minutes.

FUNCTION DIAGRAMS

MVM 315

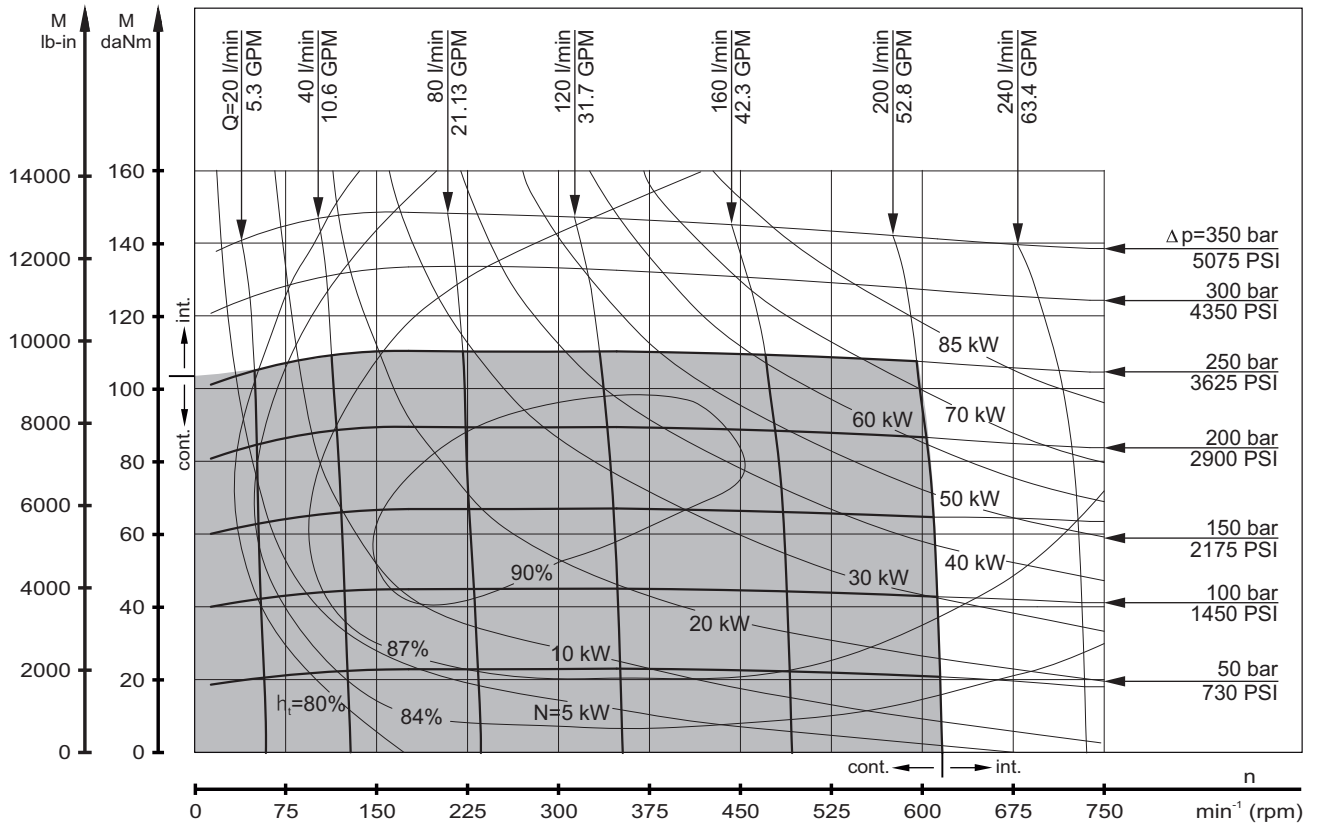

MVM 400

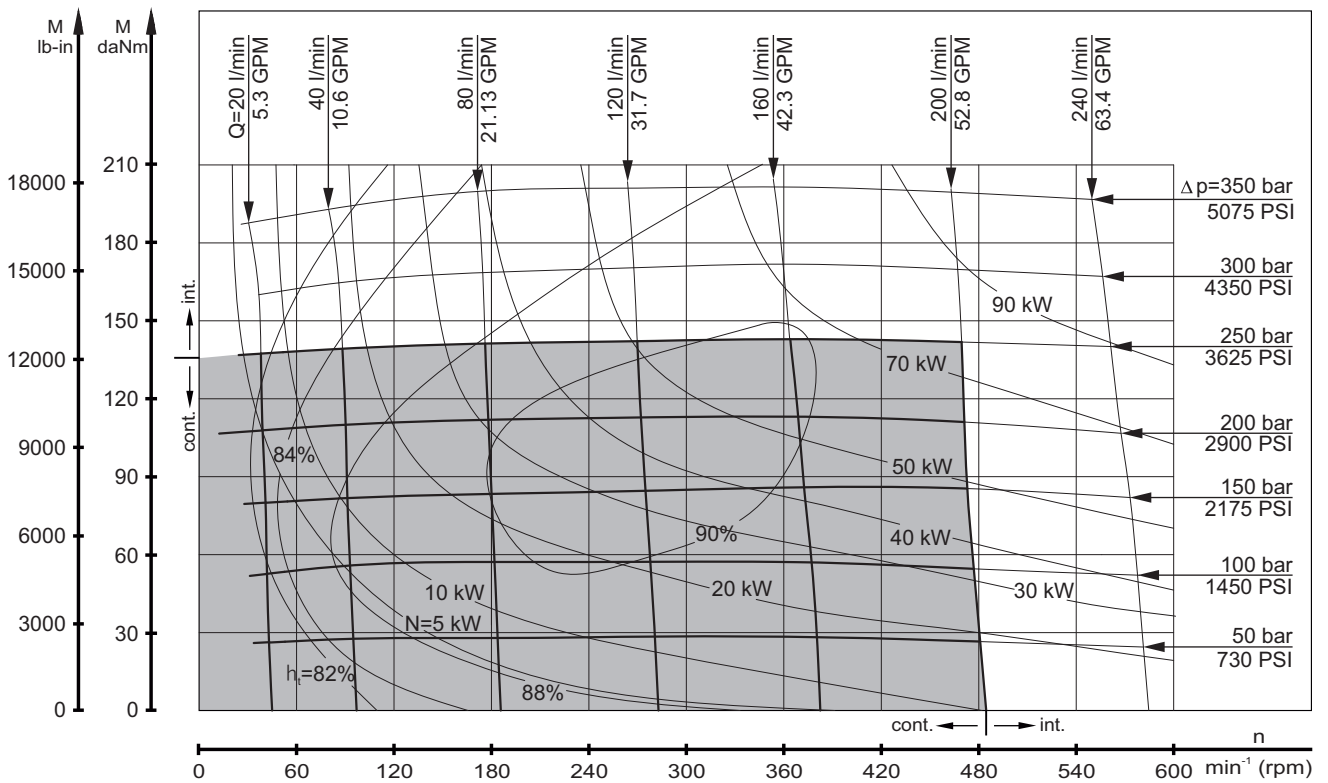

The function diagrams data was collected at back pressure 72.5÷145 PSI [5÷10 bar] and oil with viscosity of 150 SUS [32 mm²/s] at 122°F [50°C].

FUNCTION DIAGRAMS

MVM 500

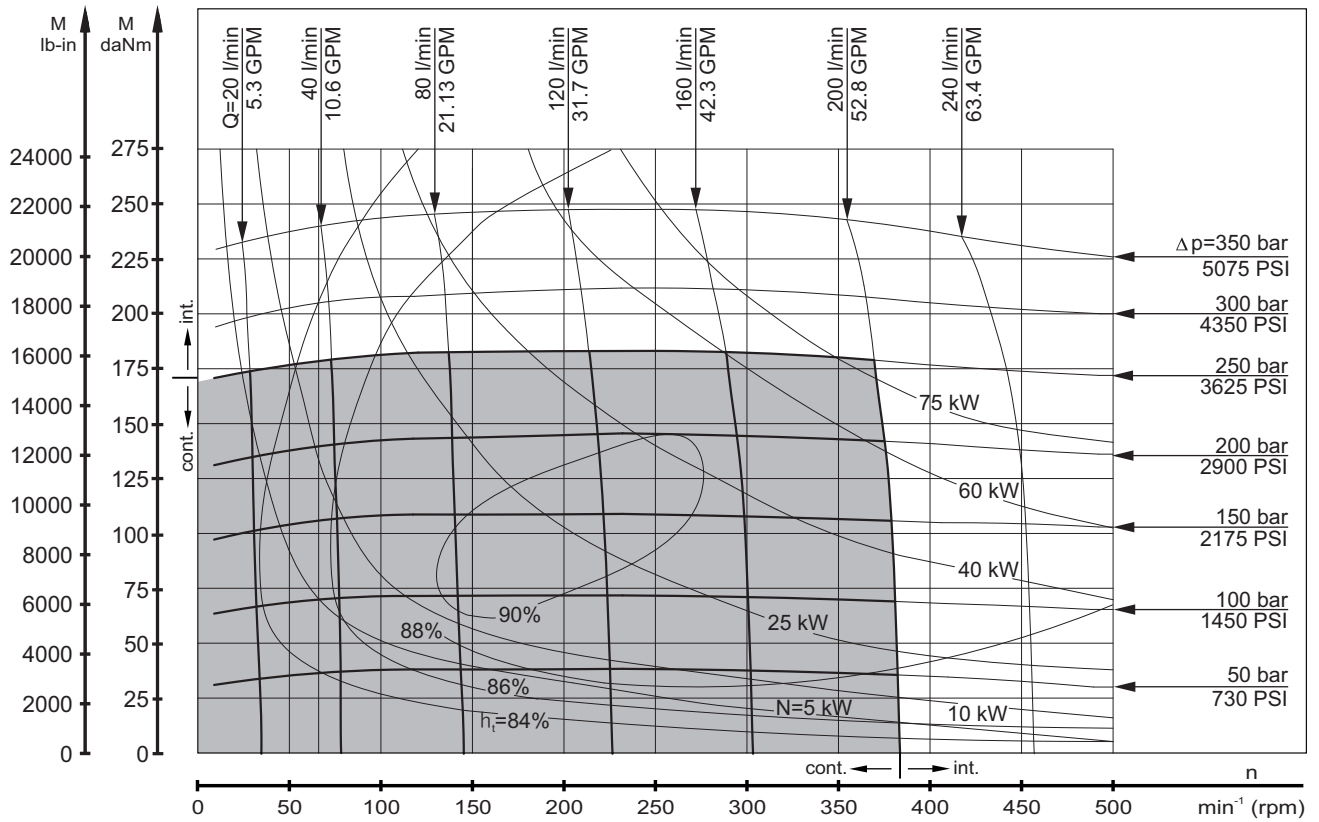

MVM 630

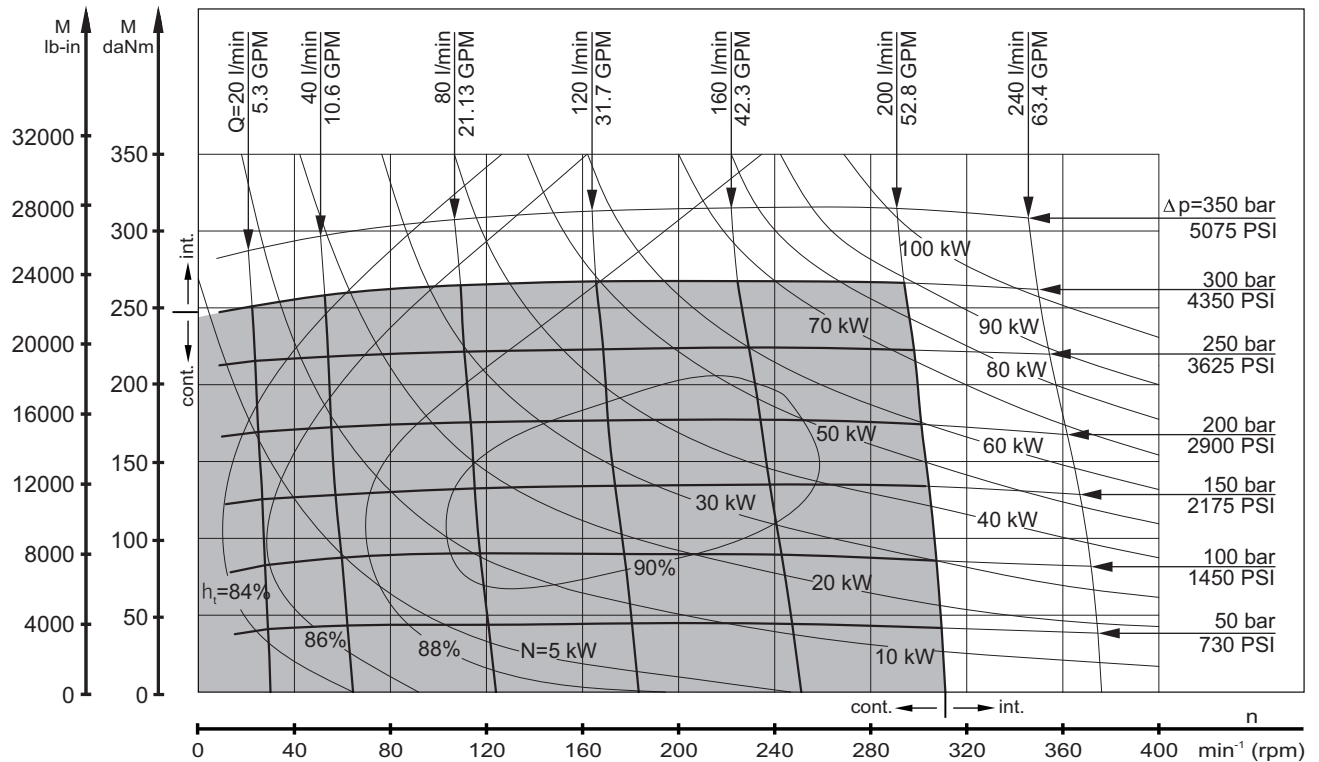

The function diagrams data was collected at back pressure 72.5+145 PSI [5+10 bar] and oil with viscosity of 150 SUS [32 mm²/s] at 122°F [50°C].

FUNCTION DIAGRAMS

MVM 800

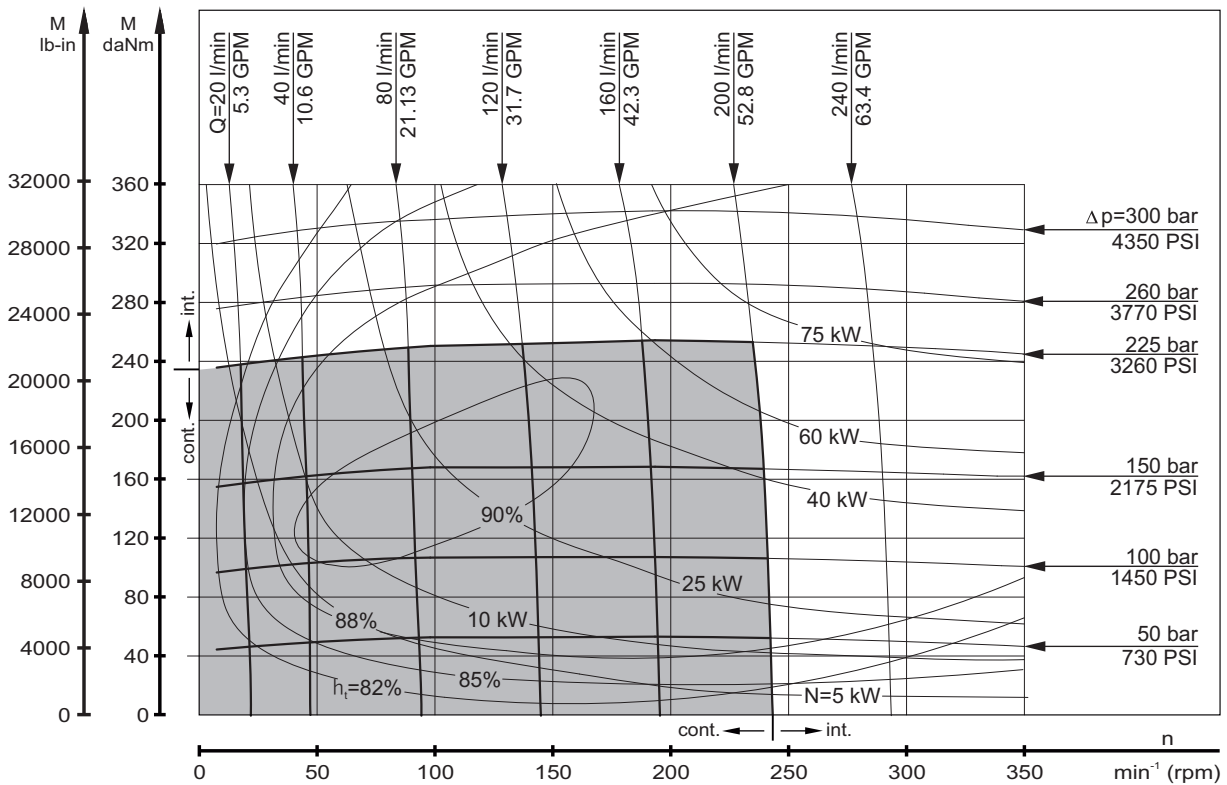

The function diagrams data was collected at back pressure 72.5÷145 PSI [5÷10 bar] and oil with viscosity of 150 SUS [32 mm²/s] at 122°F [50°C].

PERMISSIBLE SHAFT LOADS

The output shaft runs in tapered bearings that permit high axial and radial forces. Curve "1" shows max. radial shaft load. Any shaft load exceeding the values shown by the curve will seriously reduce motor life. The two other curves apply to a B10 bearing life of 3000 hours at 200 RPM.

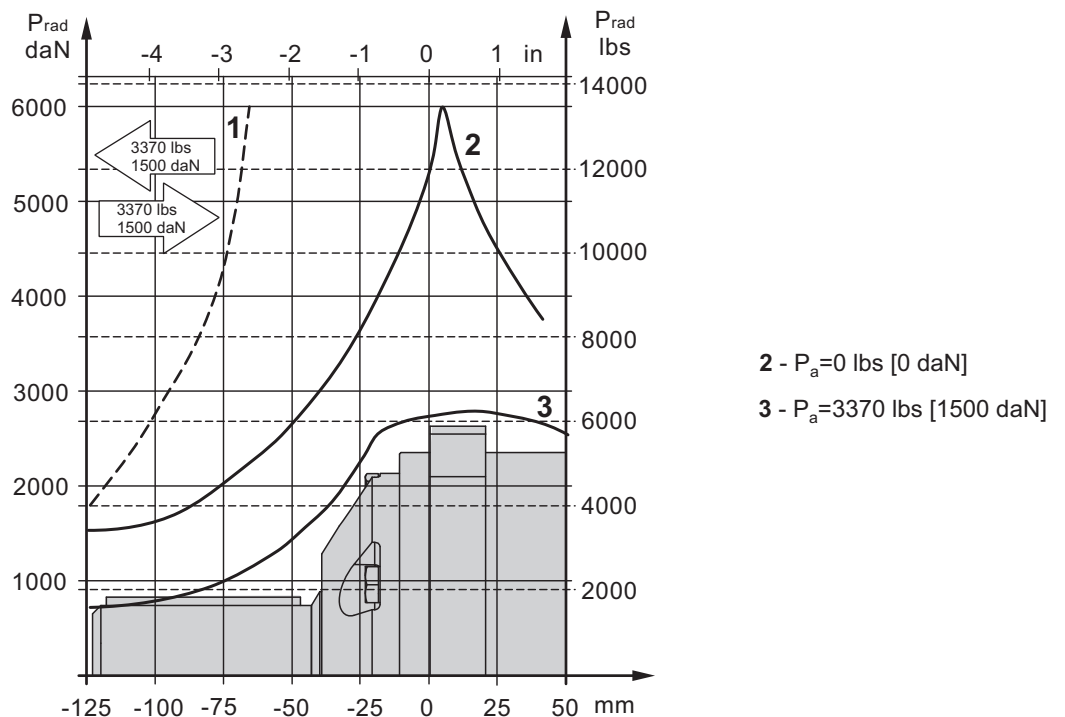

2 - $P_a=0$ lbs [0 daN]
3 - $P_a=3370$ lbs [1500 daN]

DIMENSIONS AND MOUNTING DATA MVM and MVMC

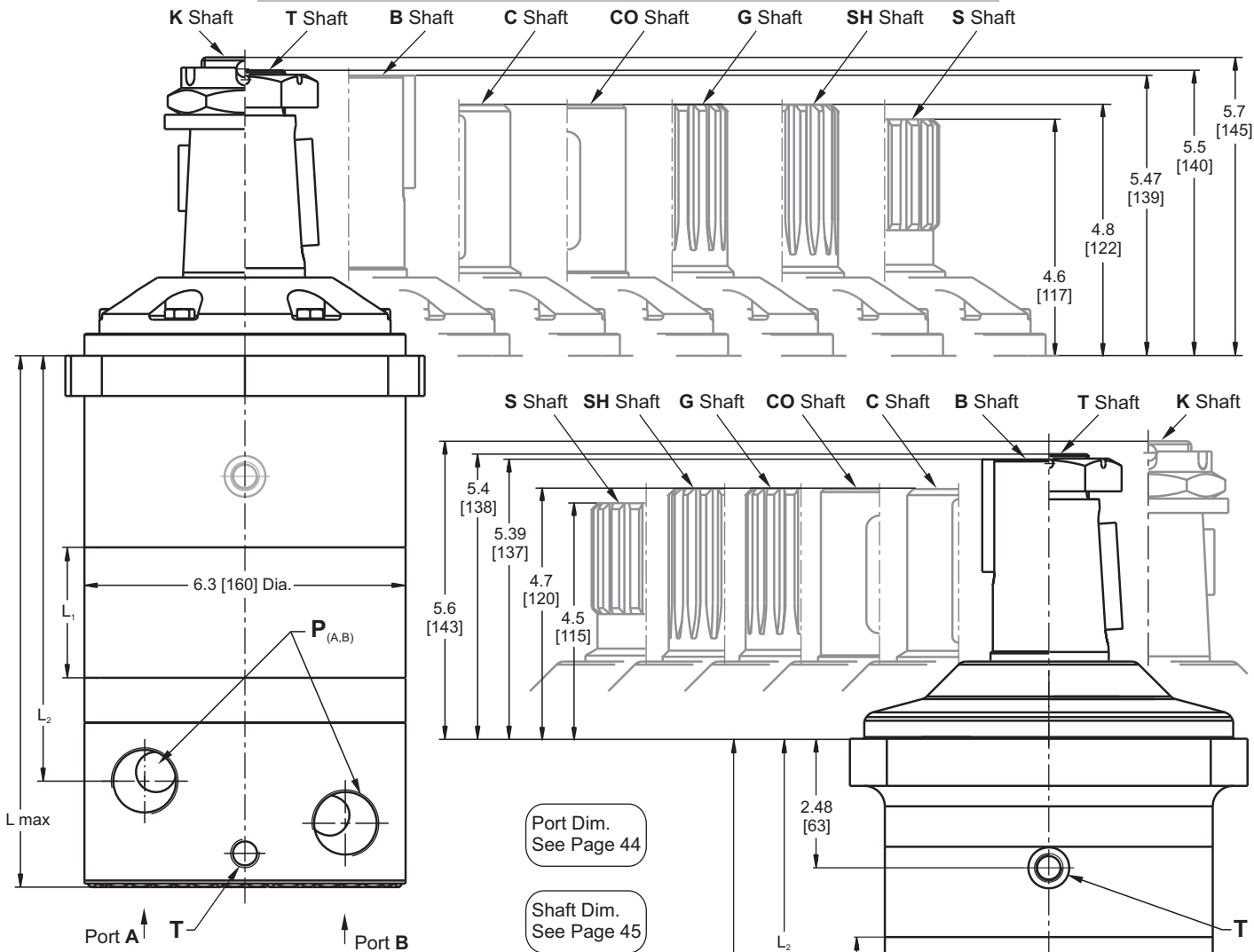

Warning: Drain line should always be used (if no check valves)!



	Versions			
	2	3	4	5
P_(A,B)	2xG1 20 mm [.787] depth	2xG1 20 mm [.787] depth	2x1 5/16-12UN 20 mm [.787] depth	2x1" (SAE PSI3000)
T	G 1/4 12 mm [.472] depth	G 1/4 12 mm [.472] depth	9/16-18UNF 13 mm [.512] depth	G 1/4 12 mm [.472] depth
C	-	6xM10 15 mm [.59] depth	-	8xM10 13 mm [.512] depth

Standard Rotation
Viewed from Shaft End
Port A Pressurized - CW
Port B Pressurized - CCW

Reverse Rotation
Viewed from Shaft End
Port A Pressurized - CCW
Port B Pressurized - CW

Type	Lmax, in [mm]	L2, in [mm]	L3, in [mm]	Type	Lmax, in [mm]	L2, in [mm]	L3, in [mm]	L1, in [mm]
MVM 315	8.92 [226,5]	6.79 [172,5]	6.20 [157,4]	MVMC 315	8.957 [227,5]	6.84 [173,8]	6.25 [158,7]	1.00 [25,5]
MVM 400	9.19 [233,5]	7.07 [179,5]	6.47 [164,4]	MVMC 400	9.232 [234,5]	7.12 [180,8]	6.52 [165,7]	1.28 [32,5]
MVM 500	9.51 [241,5]	7.38 [187,5]	6.79 [172,4]	MVMC 500	9.547 [242,5]	7.43 [188,8]	6.84 [173,7]	1.59 [40,5]
MVM 630	9.92 [252,0]	7.79 [198,0]	7.20 [182,9]	MVMC 630	9.961 [253,0]	7.85 [199,3]	7.25 [184,2]	2.01 [51,0]
MVM 800	10.47 [266,0]	8.35 [212,0]	7.75 [196,9]	MVMC 800	10.518 [267,0]	8.39 [213,3]	7.80 [198,2]	2.56 [65,0]

MOUNTING

Square Mount (4 Holes)

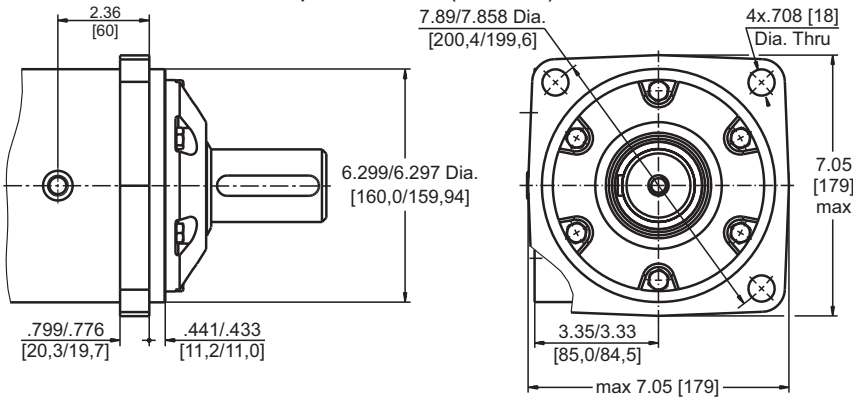

C Square Mount (four holes)

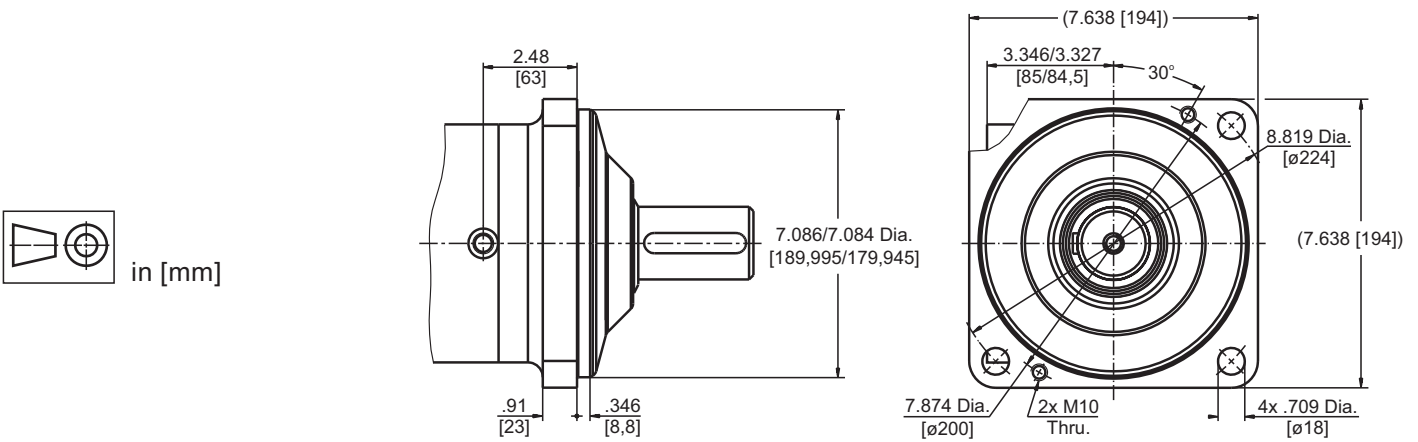

PORTS

Side Ports

Versions **2** **4**

Versions **3**

Versions **5**

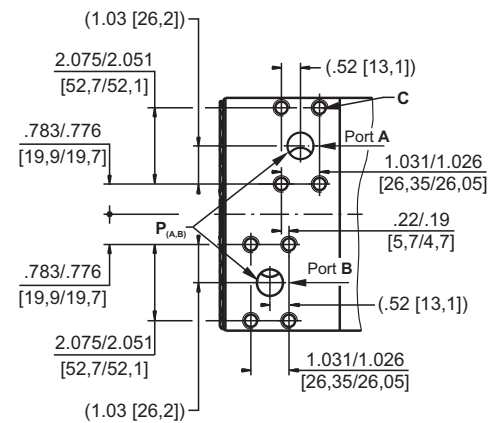
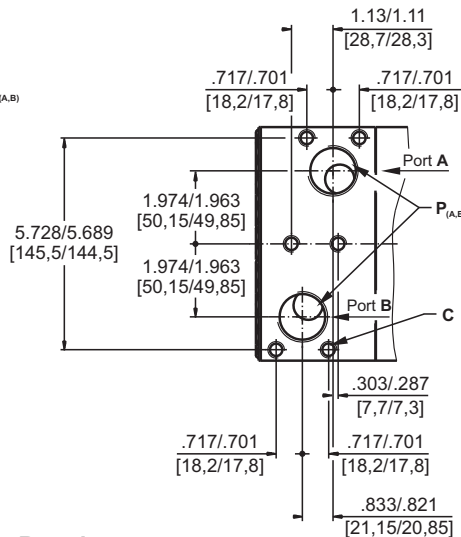
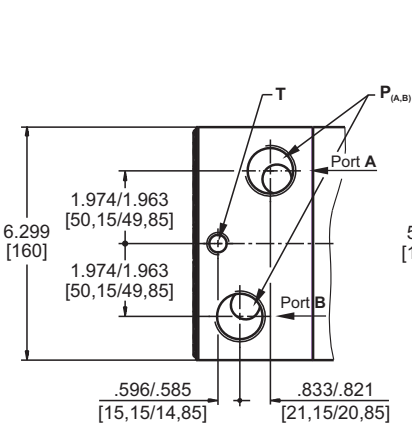

Standard Rotation

Viewed from Shaft End
Port A Pressurized - CW
Port B Pressurized - CCW

Reverse Rotation

Viewed from Shaft End
Port A Pressurized - CCW
Port B Pressurized - CW

	Versions			
	2	3	4	5
P_(A,B)	2xG1	2xG1	2x1 ⁵ / ₁₆ -12UN	2x1" (SAE PSI3000)
T	G ¹ / ₄	G ¹ / ₄	9 ¹⁶ -18UNF	G ¹ / ₄
C	-	6xM10	-	8xM10

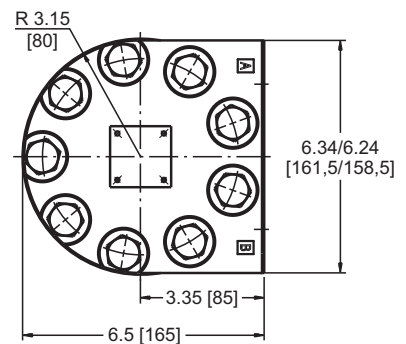

SHAFT EXTENSIONS

C - $\varnothing 50$ straight, Parallel key A14x9x70 DIN 6885
Max. Torque 24000 lb-in [271,2 daNm]

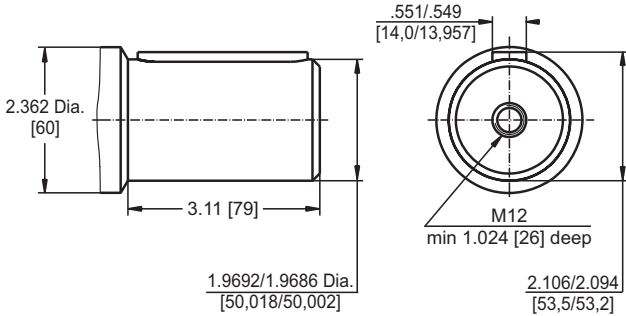

CO - $\varnothing 2\frac{1}{4}$ " [57,15] straight, Parallel key $\frac{1}{2}$ "x $\frac{1}{2}$ "x $2\frac{1}{4}$ " BS46
Max. Torque 24000 lb-in [271,2 daNm]

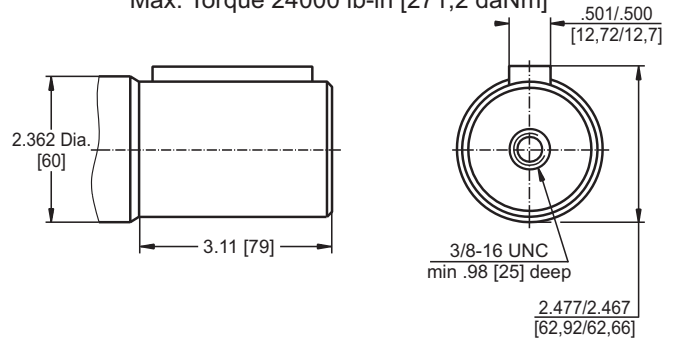

SH - $\varnothing 2\frac{1}{8}$ " ($\varnothing 53,975$) splined 16 DP 8/16 ANS B92.1-1976
Max. Torque 24000 lb-in [271,2 daNm]

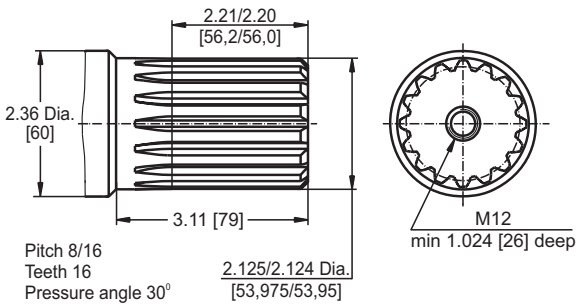

B - $\varnothing 2\frac{1}{4}$ " [57,15] straight, Parallel key $\frac{1}{2}$ "x $\frac{1}{2}$ "x $2\frac{1}{4}$ " BS46
Max. Torque 24000 lb-in [271,2 daNm]

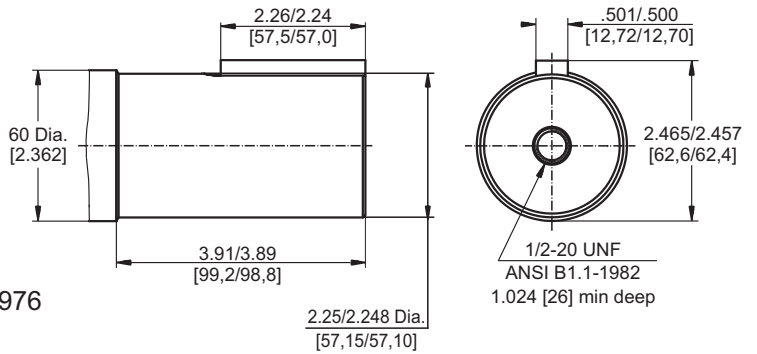

G - $\varnothing 2\frac{1}{8}$ " ($\varnothing 53,975$) splined 16 DP 8/16 ANS B92.1-1976
Max. Torque 24000 lb-in [271,2 daNm]

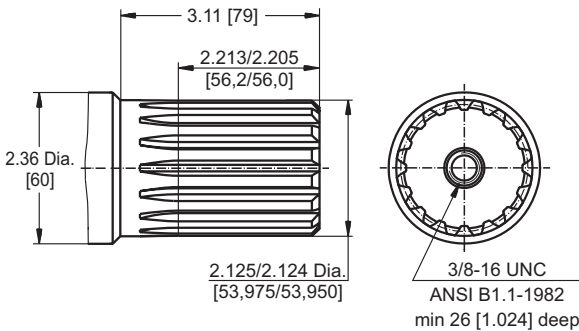

K - $\varnothing 60$, tapered 1:10, Parallel key B16x10x32 DIN 6885
Max. Torque 24000 lb-in [271,2 daNm]

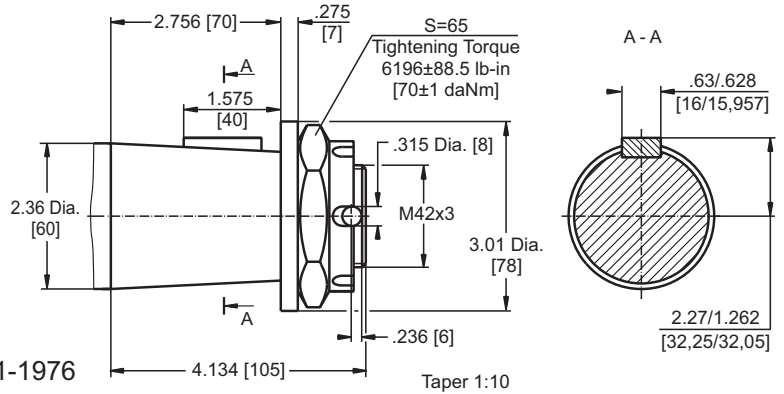

S - $\varnothing 2\frac{1}{8}$ " ($\varnothing 53,975$) splined 16 DP 8/16 ANS B92.1-1976
Max. Torque 24000 lb-in [271,2 daNm]

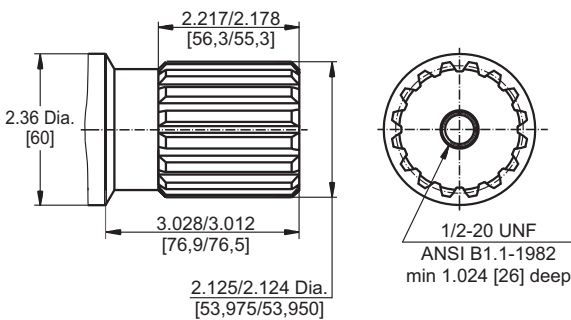

T - $\varnothing 2\frac{1}{4}$ " [57,15] SAE J501, tapered 1:8, key $\frac{9}{16}$ "x $\frac{9}{16}$ "x2" BS46
Max. Torque 24000 lb-in [271,2 daNm]

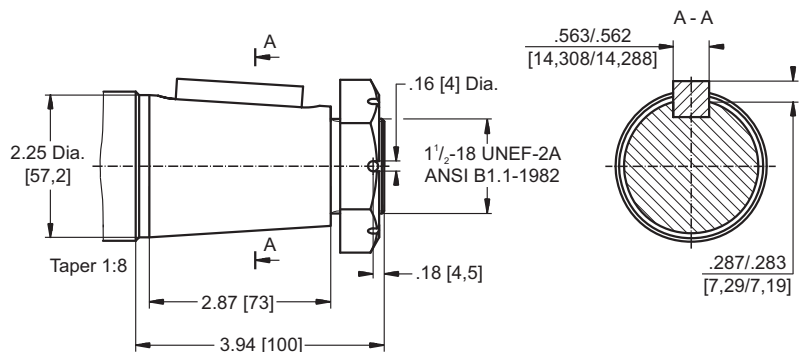

MAX. PERMISSIBLE SHAFT SEAL PRESSURE

Max. return pressure without drain line or
max. pressure in the drain line

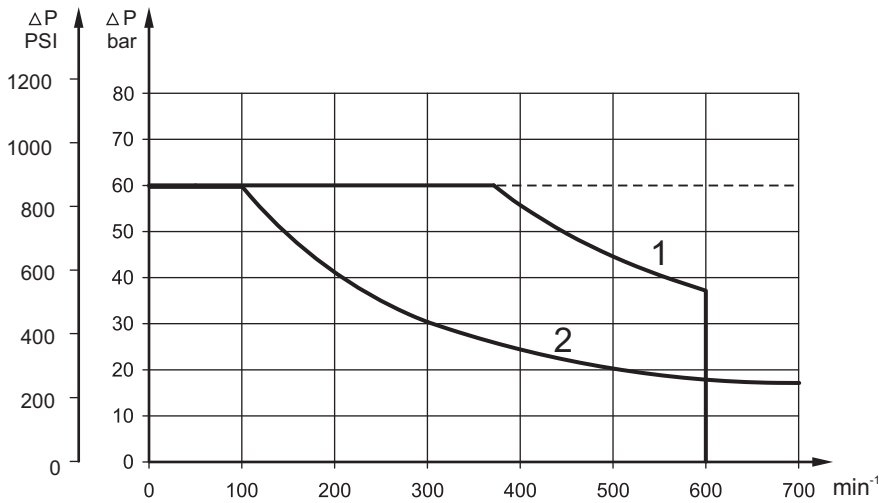

1: Drawing for High Pressure Seal ("U" Seal)
2: Drawing for Standard Shaft Seal

— - continuous operations
- - - - - intermittent operations

ORDER CODE

	1	2	3	4	5	6	7	8
M V M							HD	

Pos.1 - Mounting Flange

omit - Standard square mount, four holes

C - Square mount, four holes

Pos.2 - Displacement code

315 - 19.80 in³/rev [314,5 cm³/rev]

400 - 24.45 in³/rev [400,9 cm³/rev]

500 - 30.48 in³/rev [499,6 cm³/rev]

630 - 38.38 in³/rev [629,1 cm³/rev]

800 - 48.91 in³/rev [801,8 cm³/rev]

Pos.3 - Shaft Extensions*

C - ø50 straight, Parallel key A14x9x70 DIN6885

CO - ø2¼" [57,15] straight, Parallel key ½"x½"x2¼" BS46

B - ø2¼" [57,15] straight, Parallel key ½"x½"x2¼" BS46

SH - ø2⅛" [53,975] splined, 16DP 8/16 ANS B92.1-1976

G - ø2⅛" [53,975] splined, 16DP 8/16 ANS B92.1-1976

S - ø2⅛" [53,975] splined, 16DP 8/16 ANS B92.1-1976

K - ø60 tapered 1:10, Parallel key B16x10x32 DIN6885

T - ø2¼" [57,15] SAE J501, tapered 1:8,
key 9/16"x9/16"x2" BS46

Pos.4 - Ports

2 - side ports 2xG1, G1/4, BSP thread, ISO 228

3 - side ports 2xG1, G1/4, BSP thread, ISO 228,
6xM10

4 - side ports 2x1 5/16-12 UN, O-ring, 9/16-18 UNF

5 - side ports 2x1" (SAE PSI3000), G1/4,
BSP thread, SO 228, 8xM10

Pos.5 - Check Valves

omit - without check valves

1 - with check valves

Pos.6 - Shaft Seal Version

omit - Low pressure shaft seal

U - High pressure shaft seal

Pos.7 - Special Features

HD - Reinforced motor HD**

For Other **Special Features** see page 53

Pos.8 - Design Series

omit - Factory specified

NOTES:

* The permissible output torque for shafts must not be exceeded!

** Drain line should always be used (if no check valves).

The hydraulic motors are manganese-phosphated as standard.